



Alliance for  
Internet of Things  
Innovation

---

# IoT Relation and Impact on 5G

Release 3.0

AIOTI WG03 – IoT Standardisation

April 2020

## Executive Summary

This report highlights several IoT vertical domain use cases collected by AIOTI (Alliance for IoT Innovation) and determines the specific requirements they impose on the underlying network infrastructure. These use cases and requirements can be used by SDOs (Standards Developing Organizations), such as 3GPP (3rd Generation Partnership Project), ITU-T and IEEE as requirements for automation in vertical domains focusing on critical communications.

# Table of Contents

<b>1</b>	<b>Introduction.....</b>	<b>6</b>
<b>2</b>	<b>IoT Use Cases and Requirements .....</b>	<b>7</b>
2.1	Smart Mobility .....	8
2.1.1	Automated Valet Parking (AVP).....	8
2.1.2	Car Rebalancing.....	13
2.1.3	Car Sharing .....	17
2.1.4	Highway Pilot.....	20
2.1.5	Platooning.....	24
2.1.6	Urban Driving.....	29
2.1.7	Vehicle Monitoring .....	33
2.2	Smart City.....	39
2.2.1	Public Warning System in critical infrastructures.....	39
2.2.2	Unmanned Aerial Vehicles (UAV) as Multi-access Edge Computing (MEC) Nodes for Emergency Operations Support .....	42
2.2.3	UAS (Unmanned Aerial System) operations in U-Space .....	47
2.3	Smart Energy.....	51
2.3.1	Future Energy Grids.....	51
2.3.2	Home Energy Display .....	53
2.4	Smart Agriculture .....	58
2.4.1	Smart Irrigation .....	58
2.4.2	Precision Livestock Farming .....	64
2.5	Smart Manufacturing .....	72
2.5.1	Communication in car manufacturing.....	72
2.5.2	High performance manufacturing.....	77
2.5.3	Mobile control with safety .....	81
2.5.4	“All-Stop” in Mining and Construction Site Applications .....	84
2.6	Smart Health.....	88
2.6.1	Intelligent Emergency Response Systems .....	88
2.7	Cross-vertical .....	91
2.7.1	Siemens White Paper “5G communication networks: Vertical industry requirements” .....	91
2.7.2	Tactile Internet Use Case .....	93
2.7.3	Holographic Meetings.....	96
<b>3</b>	<b>Emerging Topics.....</b>	<b>100</b>
3.1	Tactile Internet of Things .....	101
3.2	ETSI ITS G5 versus 3GPP LTE-V2X (based on EC H2020 AUTOPILOT project) .....	104
3.3	5G Non-public Networks and Network Slicing .....	110
3.3.1	5G non-public networks .....	110
3.3.2	5G network slicing .....	111
3.4	Overview of the 'Green Deal' .....	112
3.4.1	Climate neutral Europe.....	113
3.4.2	Sustainable industry and Circular economy.....	113
3.4.3	Buildings renovation and retrofitting .....	114
3.4.4	Eliminating pollution.....	114
3.4.5	Ecosystems & biodiversity .....	115
3.4.6	Farm to fork strategy .....	115
3.4.7	Sustainable mobility.....	116
3.4.8	R&D and innovation.....	116
3.5	IoT and 5G frequency spectrum.....	117
3.6	5G promise towards the evolving energy sector .....	122
3.6.1	Requirements for Smart Grids - Convergence between electric distribution and communication infrastructures. ....	124
<b>4</b>	<b>Conclusions .....</b>	<b>125</b>
	<b>About AIOTI .....</b>	<b>141</b>

## Table of Figures

Figure 2-1: Automated Valet Parking sequence, based on EC H2020 AUTOPILOT project.....	8
Figure 2-2: Example of IoT data streams and corresponding communication networks, based on EC H2020 AUTOPILOT project.....	11
Figure 2-3: Sensors used in a parking garage, based on EC H2020 AUTOPILOT project .....	11
Figure 2-4: Example of IoT data streams and corresponding communication networks, based on EC H2020 AUTOPILOT project.....	16
Figure 2-5: Example of IoT data streams and corresponding communication networks, based on EC H2020 AUTOPILOT project.....	19
Figure 2-6: Example of IoT data streams and corresponding communication networks, based on EC H2020 AUTOPILOT project.....	23
Figure 2-7: Platooning vehicles on public road, lead vehicle has driver .....	24
Figure 2-8: Platooning trucks on public road, lead vehicle has driver .....	25
Figure 2-9: Data flows in platooning, based on EC H2020 AUTOPILOT project .....	28
Figure 2-10: Urban driving scenario, based on EC H2020 AUTOPILOT project .....	30
Figure 2-11: Example of IoT data streams and corresponding communication networks, based on EC H2020 AUTOPILOT project.....	32
Figure 2-12: Vehicle Monitoring - High level illustration.....	35
Figure 2-13: UAV as MEC nodes for emergency support operations - High level illustration.....	45
Figure 2-14: UAS operation in U-Space - High level illustration .....	49
Figure 2-15: The energy uses cases highlighting the smart assets use cases and the energy, distribution use case from smart grids, copied from [6].....	52
Figure 2-16: Energy monitoring and data flow of the Making-City project for automation and home display – Case of Oulu city. [45] D2.20 – Services and Modules for Oulu ICT Platform.....	56
Figure 2-17: Smart irrigation - High level illustration .....	60
Figure 2-18: Data-centric livestock farm management .....	64
Figure 2-19: Example of IoT data streams and corresponding communication networks .....	66
Figure 2-20: Example of a System-of-systems to an IoT based a data-centric livestock farm management.....	66
Figure 2-21: LTE-Advanced Pro features and 5G requirements [9] .....	69
Figure 2-22: IEEE 802.1AS clock synchronization .....	79
Figure 2-23: Example for time-aware scheduling with absolute time bounds.....	79
Figure 2-24: “All-Stop” in Mining and Construction Site Applications - High Level Illustration.....	85
Figure 2-25 Example of depicting the vision of the Tactile Internet.....	94
Figure 2-26: Tactile Internet latency requirement.....	94
Figure 2-27: Two persons interacting over a network feeling real meeting .....	98
Figure 3-1 Tactile IoT model (Source: adapted from Prof Eckehard Steinbach, TU Munich) .....	102
Figure 3-2: Roadmap for development and deployment of V2X and C-V2X technologies, based on 3GPPP and EC H2020 AUTOPILOT project.....	107
Figure 3-3: Autonomous vehicle domains of interaction and communication channels, based on EC H2020 AUTOPILOT project.....	108
Figure 3-4: EU-Energy and Climate Targets 2018/2019 / Source: European Commission 2019 .....	112
Figure 3-5: 5G technologies heterogeneous requirements .....	117
Figure 3-6: Three ranges of the frequency spectrum for 5G technologies.....	118
Figure 3-7: Global 5G Spectrum – Allocated or targeted frequency bands around the world.....	119
Figure 3-8: Frequency bands identified by the WRC-19 for the deployment of 5G networks.....	120
Figure 3-9: System of System approach VISION2050 .....	123
<b>Figure 3-10 New data sources in distribution grid operator's networks.....</b>	<b>123</b>
<b>Figure 3-11 Scheme of flexibility means for electricity grid operators.....</b>	<b>125</b>

# Abbreviations

3GPP	3 <sup>rd</sup> Generation Partnership Project
4G	4 <sup>th</sup> Generation
5G	5 <sup>th</sup> Generation
ABS	Anti-lock Braking System
ADApp	Autonomous Driving Application
AGV	Automated Guided Vehicle
AIOTI	Alliance for IoT Innovation
App	Application
AS	Application Server
AVP	Automated Valet Parking
BVLOS	Beyond Vision Line of Sight
CAD	Connected and Automated Driving
CAGR	Compound Annual Growth Rate
CAM	Cooperative Awareness Message
CAPEX	Capital Expenditure
CSS	Car Sharing Service
C-ITS	Cooperative-Intelligent Transportation System
D2X	Device to everything
eMBB	Enhanced Mobile Broadband
EPON	Ethernet Passive Optical Network
ETSI	European Telecommunications Standards Institute
GPS	Global Positioning System
GSM	Global System for Mobile communications
IIoT	Industrial Internet of Things
IP	Internet Protocol
IoRT	Internet of Robotic Things
IoT	Internet of Things
ITS	Intelligent Transportation System
LDM	Local Dynamic Map
LOS	Line Of Sight
LP-WAN	Low Power Wide Area Network
LTE	Long Term Evolution
LTE-V2X	LTE Vehicle to Everything
mMTC	Machine-Type Communications
NB-IoT	Narrowband IoT
NoLOS	Non Line of Sight
OBU	On-Board Unit
OGC	Open Geospatial Consortium
OPEX	Operational Expenditure
RSU	Road Side Unit
SAS	Service Alerting System
SCADA	Supervisory Control and Data Acquisition
TC	Technical Committee
TCP	Transmission Control Protocol
TIIoT	Tactile Internet of Things
MEC	Multi-Access Edge Computing
SDO	Standards Developing Organizations
TMC	Traffic Management Center
XML	Extensible Markup Language
UAV	Unmanned Aerial Vehicle
UAS	Unmanned Aerial System
UMTS	Universal Mobile Telecommunication System
uRLLC	Ultra-reliable and Low-latency Communications
UTM	Unmanned Traffic Management system
V2V	Vehicle to Vehicle
VRU	Vulnerable Road Users
WAVE	Wireless Access in Vehicular Environments
WiMAX	Worldwide Interoperability for Microwave Access

# 1 Introduction

The Internet of Things is projected to consist of 50 billion devices by 2020 [2] ranging from connected temperature sensors to autonomous vehicles. The vast scope of different device types from different verticals corresponds with highly diverse requirements for the communication infrastructure. While battery-driven sensors need a highly energy efficient communication technology, industrial IoT applications call for ultra-reliable connections with a minimum latency. As of today these diverse requirements are covered by several wireless communication technologies (e.g. (Wireless Local Access Network) WLAN, Sigfox®, ZigBee, LoRa Wide Area Network (LoRaWAN), Narrowband-IoT (NB-IoT)) which all have their specific strengths and weaknesses and that are making the Internet of Things somewhat of a “rag rug”.

This is where 5<sup>th</sup> Generation (5G) becomes to be relevant, with its highly flexible architecture designed to be adaptable to almost any use case in the IoT space using advanced techniques like network slicing and Network Function Virtualization (NFV), see e.g., [1], [5]. By offering a unified communications platform for the IoT, 5G has the potential of being a catalyst for IoT growth – and vice versa.

Compared with previous generations of mobile technologies, 5G systems will extend mobile communication services beyond mobile telephony, mobile broadband, and massive machine-type communication into new application domains, so-called vertical domains.

The main goal of this report is to highlight specific IoT vertical domain use cases and determine the specific requirements they impose on the network infrastructure. These use cases and requirements can be used by SDOs (Standards Developing Organizations), such as 3<sup>rd</sup> Generation Partnership Project (3GPP), ITU-T and IEEE as requirements for automation in vertical domains focusing on critical communications.

Release 2.0, compared to Release 1.0, includes 6 additional use cases, where 4 of them are summaries of use cases defined by 3GPP SA1. Moreover, a sub-section on emerging topics has been added that are related to IoT and can impact the specifications and deployments of 5G.

The six additional use cases described in Release 2.0 are:

- Precision Livestock Farming (Smart Agriculture)
- Communication in car manufacturing (Smart Manufacturing, summary from 3GPP SA1 [15])
- High performance manufacturing (Smart manufacturing, summary from 3GPP SA1 [16])
- Mobile control with safety (Smart Manufacturing, summary from 3GPP SA1 [15])
- Intelligent Emergency Response Systems (Smart Health, summary from 3GPP SA1 [18])

- Tactile Internet Use Case (Cross-vertical)

Release 3.0, compared to Release 2.0, includes 3 additional use cases and 3 new sub-sections on emerging topics.

The 3 additional use cases described in Release 3.0 are:

- Home Energy Display (Smart Energy type of use case);
- Holographic Meetings (Cross-vertical type of use case);
- All-Stop” in Mining and Construction Site Applications (Smart Manufacturing type of use case).

The 3 additional sub-sections on emerging topics are:

- Overview of the 'Green Deal';
- IoT and 5G frequency spectrum;
- 5G promise towards the evolving energy sector.

In subsequent versions of this report, these requirements will be mapped to the 5G features according to the current 3GPP design documents and subsequently analyse potential gaps of 5G related to IoT use case requirements and give recommendations on how to close these gaps.

## 2 IoT Use Cases and Requirements

This section describes the IoT vertical domain use cases that are being developed in IoT focused projects. Moreover, this section describes the specific requirements that these use cases impose on the underlying network infrastructure.

The use cases listed in this section have been described using the use case description template provided in Annex II.

## 2.1 Smart Mobility

### 2.1.1 Automated Valet Parking (AVP)

#### 2.1.1.1 Description

The concept of Valet Parking is widely used all over the world; for example, by the more luxurious hotels and restaurants, stores and other businesses.

Once a customer arrives with his/her vehicle at the hotel, he/she gets out of the vehicle and hands over the car-keys to the hotel personnel, which will then drive the vehicle to its parking spot, relieving the customer from that task. In the meantime, the owner of the vehicle can e.g. check-in or attend a meeting. Likewise, the vehicle is returned by the hotel personnel upon the request of the relevant customer. Utilising the technology evolution of self-driving vehicles, it is a logical next step to also automate the valet parking concept, further referred to as Autonomous Valet Parking, or AVP.

By deploying this use case several stakeholder types can participate and profit from its value chain, such as: Autonomous Valet Parking application provider, IoT Devices manufacturer, Communication Network supplier/provider/operator and IoT platform provider.

In this use case, IoT plays an important role being applied to improve the operation of an autonomous driving vehicle when used in Valet Parking scenarios.

In AVP, see Figure 2-1, the autonomous vehicle will park itself after the driver has left the car (step 1) at a drop-off point, which may be located near the entrance of a parking lot. The autonomous vehicle will find an available parking spot (step 2) and drive and park itself (step 3). When the driver wants to leave the site, he/she will simply request from the autonomous vehicle to return by itself (step 4) to the collect point, using (for example) a Smartphone app.

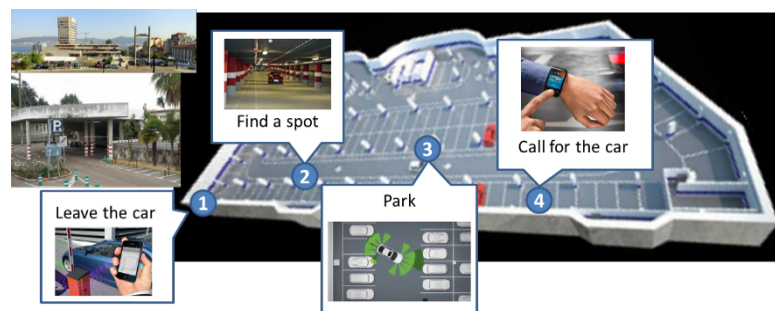

Figure 2-1: Automated Valet Parking sequence, based on [EC H2020 AUTOPILOT project](#)



To navigate safely around the parking lot to its destination, the automated vehicle uses driving functions based on knowledge about the environment around the vehicle. An example would be a navigation functionality based on a digital map, positions of the automated vehicle and vacant parking spots. The vehicle can use its own functions and sensors to observe immediate environment, but it can also benefit from gathering additional data going beyond what its sensor can observe – like accessing IoT platforms which can provide data and functions based on IoT enabled sensors like parking cameras, as well as position info from other vehicles driving (or being parked) at parking. Furthermore, IoT platforms may provide information to support services for booking a parking place and arranging (automated) payment.

One of the main challenges when using IoT data as additional source, is that we need a suitable common architecture of sharing information between different sensor systems (e.g., vehicle, garage equipment), such that any vehicle can park itself in any parking garage. For scenarios in which the parking lot is equipped with an extended set of sensors, more and accurate information can be shared with the AVP-vehicle, such it can perform its task better (with shorter time to park, less fuel consumed), compared to parking lots that lack additional sensors.

#### **2.1.1.2 Source**

[EC H2020 AUTOPILOT project](#)

#### **2.1.1.3 Roles and Actors**

- Vehicle owner / driver / passenger in the vehicle: Profits from the AVP service by decreasing the required time to park the vehicle and at the same time increasing the probability of finding a free slot in the parking area and decreasing the probability of vehicle accidents in the parking area.
- Parking Owner: Profits from the AVP service on optimizing the utilization of the parking spots.
- IoT platform provider: It operates an IoT platform which is collecting data from vehicles, parking spots, roads, other participants in traffic present, and from surrounding associated infrastructure (traffic lights, cameras, etc.). Necessary information/data is provided to any devices that are subscribed to the IoT platform.
- Autonomous Valet Parking application provider: Party that is providing Automated Valet Parking application (AVPApp) which runs on AS (Application Servers). AVPApp connects to the IoT platform, and from there it collects relevant data needed to run an Autonomous Driving App (ADApp) - for example Local Dynamic Map (LDM).
- Communication Network supplier/provider/operator: Supplies and/or provides and facilitates connectivity between vehicles, roads and associated infrastructure. This covers both wireless (for example Long Term Evolution (LTE), LTE-Vehicle to Everything (LTE-V2X), Intelligent Transportation System –G5 (ITS-G5) and Wireless Access in Vehicular Environments (WAVE) and fixed connections. The Network supports receiving requests for data transfers that require low latency and low

probability of packet losses. It is not expected or mandated that a single network operator provides the end-to-end connectivity.

- IoT Devices manufacturer: Manufacturer provides IoT devices that are embedded in vehicles, roads and associated infrastructure, parking garage /terrain, traffic lights, as well as in devices used by other participants in traffic (pedestrians, cyclists). Each IoT device collects and sends data to IoT platform, and can receive data from the IoT platform.

#### **2.1.1.4 Pre-conditions**

The vehicle supports autonomous driving - meaning that it is capable of (1) autonomously driving, and (2) transmitting and receiving data from other vehicles, road and other infrastructure, and as well other participants in traffic (pedestrians, cyclists).

#### **2.1.1.5 Triggers**

The AVP function (sending vehicle to park itself, as well as calling it back to collect point) is activated by the vehicle driver.

#### **2.1.1.6 Normal Flow**

1. The vehicle continuously collects data from own sensors and sends them to the IoT platform. The transmitted data includes information from the internal state of the vehicle (Anti-lock Braking System (ABS) status, brake switch, accelerator pedal switch, etc.) as well as data on observed surroundings of the vehicle (such as radar, LIDAR, cameras).
2. Road infrastructure (such as roads, traffic lights, cameras) continuously collects data from its sensors and sends it to the IoT platform. Examples include events such as vehicles driving on top of sensors placed on the road, the state of traffic lights, the detected vehicles driving (observed by cameras).
3. Devices belonging to other participants in traffic (such as pedestrians, cyclists) continuously collect data from their sensors (such as position, accelerometers) and send it to the IoT platform.
4. The IoT platform hosts the collected data from abovementioned sources. Upon request the IoT platform will send it to AS where Automated Valet Parking application (AVPApp) is running. The AVPApp is subscribed to the IoT data from all participants in traffic in area of parking garage / terrain and immediate surroundings.
5. Processed information from AVPApp is sent back to IoT platform, and is made available to all ADApp subscribed participants in traffic.
6. Each participant in traffic is responsible for interpretation and action based on the received ADApp data.

#### **2.1.1.7 Alternative Flow**

None.

#### **2.1.1.8 Post-conditions**

Vehicle stays in autonomous driving mode until it is switched off by the driver.

### 2.1.1.9 High Level Illustration

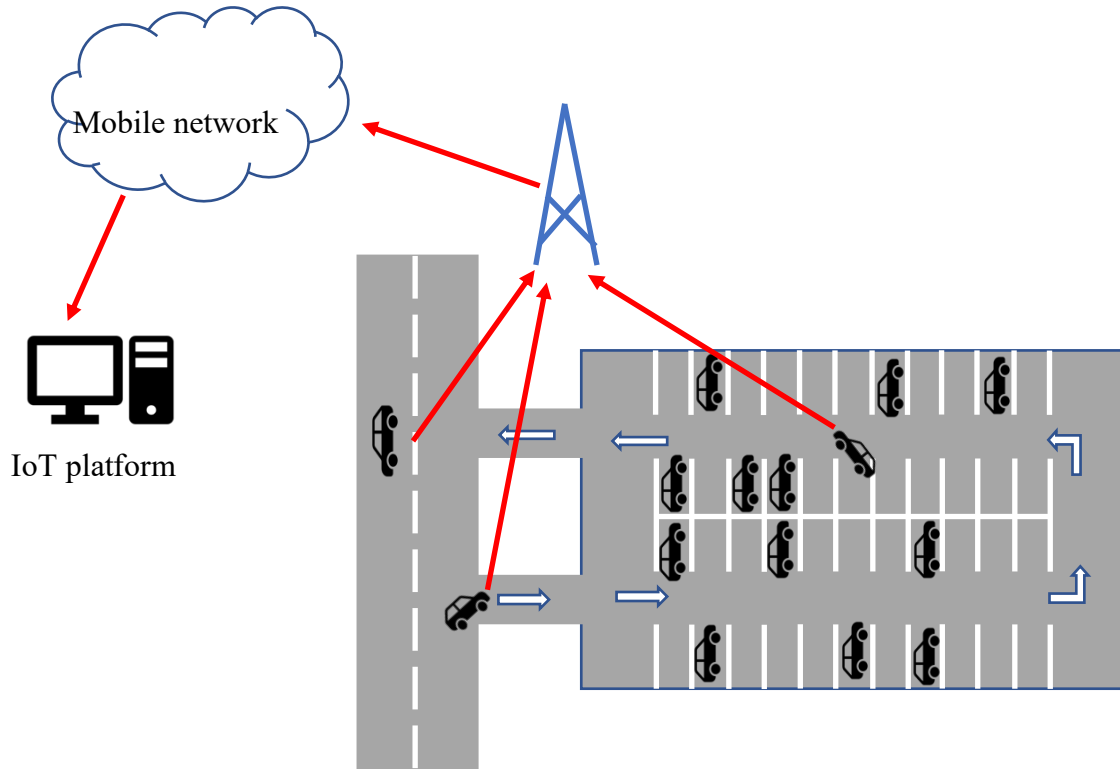

Figure 2-2: Example of IoT data streams and corresponding communication networks, based on [EC H2020 AUTOPILOT project](#)



Figure 2-3: Sensors used in a parking garage, based on [EC H2020 AUTOPILOT project](#)

### 2.1.1.10 Potential Requirements

The AVP functionality can be divided into two key components. One component is focusing on the process of autonomous driving, and the other one is responsible for providing information to vehicles on available parking spots.

The Information on available parking spots, which also possibly include route information (detailed or just waypoints) is not considered to be time critical, since it is expected that

vehicles move with low speeds within the parking terrain / garage. This route information includes start and end points, with possibly waypoints in between, and as well the whole planned / advised route to destination. Therefore, the total amount of transmitted data will not be significantly large. It is expected that current 5G promises on performance capabilities, see e.g., [1], will be able to support the performance requirements imposed by the AVP use case on the underlying communication network.

#### 2.1.1.11 Radio Specific requirements

Autonomous driving is dependent on the timely information about other participants in traffic. The [ETSI TC ITS](#) (European Telecommunications Standards Institute Technical Committee Intelligent Transport Systems) has defined a number of standards on what type of data and how often to exchange data between cooperating vehicles. These messages are typically known as CAM (Cooperative Awareness Messages), and they are sent periodically. As expected the higher the speed of the vehicle, the higher the frequency of sending CAM data. This frequency ranges from 1 Hz (period is 1000ms) to 10Hz (period is 100ms). There are also requirements supported on how long the received CAM data is valid. Effectively this is the maximal allowed end-to-end latency, which for cooperative awareness applications is around 100ms (end-to-end, including processing).

Note that for autonomous driving scenarios, one of the assumptions is that whatever the use case, a vehicle will have local (vehicle internal) intelligence to process the collected data received from own sensors and as well as from external sensors and sources, e.g., other vehicles and road side systems. Adequate strategies have been developed which allow vehicles to handle unreliable connections. It is important to note that in the EC H2020 AUTOPILOT project, it is considered that an autonomously driving vehicle will be able to autonomously operate and drive even if this vehicle is not communicating with external sensors and sources. In situations that the autonomously driving vehicle uses communication means and data generated by external sensors and sources it can make better and more accurate decisions on how to act.

Current 5G promises on performance capabilities, see Table 1, are able to support the requirements imposed by the AVP use case even on more complex and demanding processing and on supporting roadside systems to gather more data from other sensors and sources.

**Table 1: 5G promises on performance capabilities, based on [1]**

Requirement	Explicit 5G Promises
<b>Real-time capability- Latency</b>	5 ms (e2e)
<b>Reliability</b>	99.999%
<b>Outdoor terminal location accuracy</b>	<1 m
<b>Multi-tenant support</b>	yes

## 2.1.2 Car Rebalancing

### 2.1.2.1 Description

The driverless car rebalancing service is targeted to offer rebalancing of several AD vehicles distributed over several collect points within a car sharing concept. The AD vehicles will be able to drive automatically (speed limit of 10 km/h) between dedicated collect points on specific areas such as University campuses, using pre-defined and 3D-mapped tracks and IoT data to improve its world model. The scenario associated with this use case comprises areas, such as University campuses, where no lane markings, no traffic signs, no pedestrian crossings, no RSUs and no traffic lights are used and where aside from the multiple vehicles, there are several pedestrians and cyclists moving into the campus. This creates a challenging urban environment for Automated Driving vehicles.

The concept of IoT is used to connect probabilistic & historical data not available yet in AD vehicles for Urban Driving using different sources to improve the world model of an AD vehicle:

- Use campus lecture schedule data to adapt probabilistic models in the AD vehicle's World Model. Statistically predict the probability of large amount of Vulnerable Road Users (VRUs) on the roads. And so, decide when to drive and when better not to do so or adapt dynamically the vehicles driving behaviour.
- People tracking through a phone app. The app acts as position sensor and this position data facilitates data-association and tracking for improving the AD vehicle's World Model
- Get actual weather and daylight information from internet. Reconfigure sensors to better perform under various weather and daylight conditions.

The key benefits of the car rebalancing use case are:

- Increase Safety: by decreasing time to detect and avoid collisions with VRUs.
- Increase availability of vehicles in real time, i.e., min. response time between request and delivery.
- Increase utilization of parking spaces.
- Decrease the errors (i.e., false/negative events) in obstacle detection.
- Increase routing prediction, i.e., less rerouting, due to better prediction of blocked routes due to VRU detection.
- Increase localization accuracy, by using among others localisation provided by IoT enabled Smartphone apps.
- Increase dynamical obstacle motion accuracy.
- Improve prediction of demand for requested vehicles.

### 2.1.2.2 Source

[EC H2020 AUTOPILOT project](#)

### 2.1.2.3 Roles and Actors

- Vehicle owner / driver / passenger in the vehicle: The car rebalancing service provides several benefits to the vehicle owners/drivers/passengers, such as: (1) increase safety, by decreasing time to detect and avoid collisions with VRUs, (2) Increase availability of vehicles in real time, i.e., min. response time between request and delivery, (3) Decrease the errors (false/negative events) in obstacle detection, (4) Increase routing prediction, i.e., less rerouting, due to better prediction of blocked routes due to VRU detection.
- IoT platform provider: It operates an IoT platform which is collecting data from vehicles, roads, other participants in traffic present, and from surrounding associated infrastructure (such as traffic lights, cameras). Necessary information/data is provided to any devices that are subscribed to the IoT platform.
- Car rebalancing service provider: Provides the car rebalancing service. The car rebalancing service collects information on the available vehicles on each known collect points. If rebalancing is needed (i.e., vehicles need to be redistributed) then it will make use of routing and motion planning function, to lead the vehicles to the selected collect points/parking. The AD vehicle moves, using a routing and motion planning function, over the campus to the newly designated collect point/parking, using both its environmental sensors and information from IoT devices, such as (1) weather information, (2) detecting VRUs using localization provided by IoT enabled Smartphone apps and (3) TU/e lecture course scheduling.
- Communication Network supplier/provider/operator: Supplies and/or provides and facilitates connectivity between vehicles, roads and associated infrastructure. This covers both wireless (for example LTE, LTE-V2X, ITS-G5 and WAVE) and fixed connections. The Network supports receiving requests for data transfers with required latency and with required packet losses. It is not expected or mandated that single network operator provides all of connectivity.
- IoT Devices manufacturer: Manufactures IoT devices that are embedded in vehicles, roads and associated infrastructure, parking garage /terrain, traffic lights, as well as in devices used by other participants in traffic (pedestrians, cyclists). Each IoT device collects and sends data to IoT platform, and can receive data from platform.

### 2.1.2.4 Pre-conditions

The car rebalancing service can obtain vehicle information (such as current location, destination) and information on the available vehicles on each known collect points/parking, and as well the maximum capacity of the known collect points/parking.

### 2.1.2.5 Triggers

Car rebalancing service is activated when it is observed that (1) not enough vehicles are available at collect points/parking (2) a higher (than a predefined threshold) number of vehicles is parked at a collect point/parking.

#### **2.1.2.6 Normal Flow**

1. Vehicle provides to the IoT platform its current location, destination, number of available places and maybe other conditions (such as dogs accepted or not, luggage accepted or not).
2. Parking collect points/parking sends information to the IoT platform on the available vehicles on each known collect points/parking
3. Information regarding campus lecture schedule data to adapt probabilistic models in the AD vehicle's World Model is sent to the IoT platform.
4. Information regarding weather and daylight information is sent to the IoT platform.
5. VRUs: information for pedestrian detection is sent to the IoT platform.
6. The IoT platform hosts the collected data from abovementioned sources, and upon request it will send it to AS where car rebalancing application (Car rebalancing App) is running. Car rebalancing App is subscribed to the IoT data from all participants in traffic in urban area.
7. The car rebalancing service collects information on the available vehicles on each known collect points. If rebalancing is needed (i.e., vehicles need to be redistributed) then it will make use of routing and motion planning function, to lead the vehicles to the selected collect points/parking. Processed information from Car rebalancing App is sent back to IoT platform, and is made available to all Car rebalancing App subscribed participants in traffic.
8. Each participant in traffic is responsible for interpretation and action based on received Car rebalancing App data. In particular, the AD vehicle moves, using a routing and motion planning function, over the campus to the newly designated collect point/parking, using both its environmental sensors and information from IoT devices, such as (1) weather information, (2) detecting VRUs using localization provided by IoT enabled Smartphone apps and (3) TU/e lecture course scheduling

#### **2.1.2.7 Alternative Flow**

None

#### **2.1.2.8 Post-conditions**

Vehicle stays in car rebalancing mode until the car rebalancing service provider or the vehicle owner decide that the vehicle cannot support the car rebalancing service anymore;

### 2.1.2.9 High Level Illustration

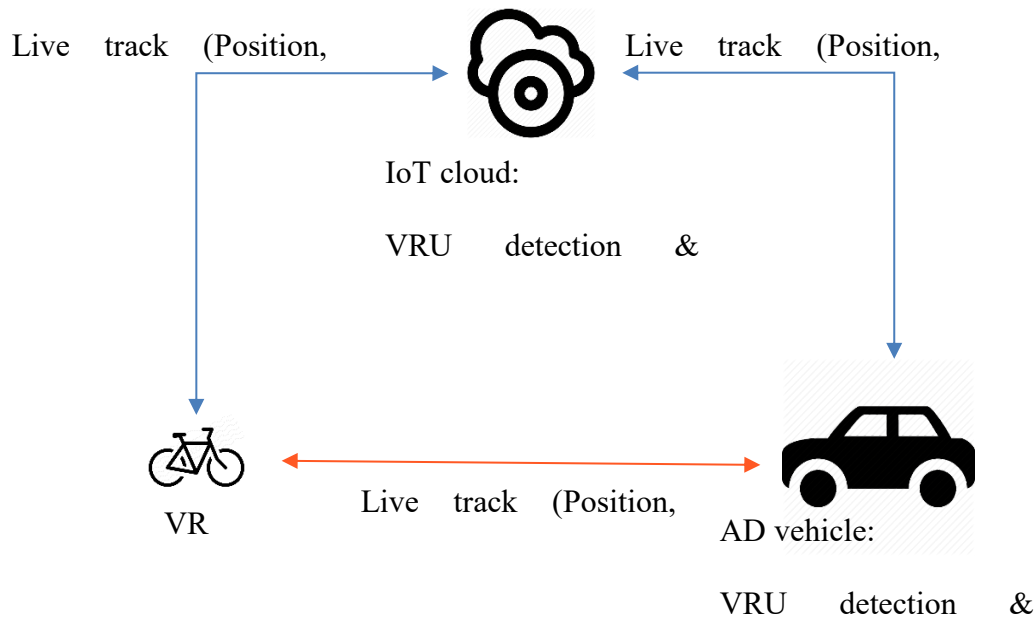

Figure 2-4: Example of IoT data streams and corresponding communication networks, based on [EC H2020 AUTOPILOT project](#)

### 2.1.2.10 Potential Requirements

Car rebalancing can be divided into two key components. One component focuses on the process of autonomous driving, and the other one is responsible to get the vehicle from its current location (typically parking terrain/ garage) to the place where it should collect the passenger, or where it should wait until the passenger arrives (for example drive during the night and park at a big parking terrain, where it will be picked up in the morning).

The distribution and collection of destination data is considered to not be time critical. The vehicle can receive the route information from the car rebalancing service, which includes the start (i.e., current vehicle's location) and end point, and possibly waypoints in between and even the whole planned / advised route to destination. In any of the above described car rebalancing scenarios, the total amount of transmitted data will not be large. Therefore, current 5G promises on performance capabilities, see Table 1, can support these requirements.

### 2.1.2.11 Radio Specific requirements

In car rebalancing, the rebalancing planning component, including the need to rebalance, and planning to destinations, is considered to not be time critical. The autonomous driving component is the one which is critical, and is therefore imposing performance requirements on the underlying communication network.

Autonomous driving is dependent on the timely information received from other participants in the traffic. As discussed in Section 2.1.1.11, it is important to note that in the EC H2020 AUTOPILOT project, it is considered that an autonomously driving vehicle will be able to autonomously operate and drive even if this vehicle is not communicating with external



sensors and sources. In situations that the autonomously driving vehicle uses communication means and data generated by external sensors and sources, it can make better and more accurate decisions on how to act.

Current 5G promises on performance capabilities, see Table 1, are able to support the requirements imposed by both the car rebalancing use case components, which are the autonomous driving and the rebalancing planning.

### 2.1.3 Car Sharing

#### 2.1.3.1 Description

A car sharing service is intended to be used as a tool to enable different customers to make use of a fleet of cars (either self-driving or not) shared amongst them. Car sharing can be interpreted as a service that finds the closest available car and assigns it to a single customer, or drive the closest available car to the interested customer. Car sharing can also be intended as ride sharing, where multiple customers that possibly have different origins and destinations share a part of the ride on a common car. Finally, car sharing services can also be considered as services that allow customers to specify pick-up and drop-off time-windows to increase flexibility and planning.

The service takes as input customers' requests, and based on those, outputs car sharing schedules (plans) including pick-up and drop-off locations and times for each passenger, itineraries, etc.

Unlike current car sharing solutions, the IoT-enabled cars will be able to compute how costly it is to pick up a given customer, in terms of time, changes in current schedule, etc., and they will send this information to the "assignment" engine. The latter will then compute the optimal car-customer matching. Moreover, cars will be able to share information relevant to each other's journeys. They will benefit from the openness of the IoT platform to receive relevant information from any device that is available in the network (traffic lights, drones, other car sensors, etc.) without the need for cars to know what each device is and/or how it operates.

Car sharing is part of the growing mobility-on-demand effort to re-think the transportation infrastructure of large urban areas. It is well-known that most urban vehicles are underutilized. A typical (urban driving) car would be confined to 20-30 km/h speeds and be parked 90% of the time.

#### 2.1.3.2 Source

[EC H2020 AUTOPILOT project](#)

#### 2.1.3.3 Roles and Actors

- Vehicle owner / driver / passenger in the vehicle: For the vehicle owner it enables him/her to own a fleet of vehicles that can be shared among a number of customers

(i.e., drivers and/or passengers). For customers (i.e., drivers and/or passengers), it enable them to make use of a fleet of vehicles (either self-driving or not) shared amongst them. Moreover, it enables customers to specify pick-up and drop-off time-windows to increase flexibility and planning.

- IoT platform provider: It operates an IoT platform which is collecting data from vehicles, roads, other participants in traffic present, and from surrounding associated infrastructure (such as traffic lights, cameras). Necessary information/data is provided to any devices that are subscribed to the IoT platform.
- Car sharing service provider: Party that is providing Car Sharing Service (CSS) which runs in cloud. CSS collects requests from users (authenticated) and matches them with vehicles (users) and their destinations. For that, it will also make use of routing function, to lead user to the rendezvous point, where it will meet / be picked up by vehicle.
- Communication Network supplier/provider/operator: Supplies and/or provides and facilitates connectivity between vehicles, roads and associated infrastructure. This covers both wireless (for example LTE, LTE-V2X, ITS-G5 and WAVE) and fixed connections. The Network supports receiving requests for data transfers with required latency and with required packet losses. It is not expected or mandated that single network operator provides all of connectivity.
- IoT Devices manufacturer: Manufactures IoT devices that are embedded in vehicles, roads and associated infrastructure, parking garage /terrain, traffic lights, as well as in devices used by other participants in traffic (such as pedestrians, cyclists). Each IoT device collects and sends data to IoT platform, and can receive data from platform.

#### **2.1.3.4 Pre-conditions**

The car sharing service can obtain vehicle information (such as current location, destination) and their preference whether they are offering car sharing or not. Moreover, the car rebalancing service can obtain information on the available vehicles on each known collect points/parking, and as well the maximum capacity of the known collect points/parking.

#### **2.1.3.5 Triggers**

The car sharing service is activated by any driver of vehicle, thus indicating that it is willing to provide this service. This information is passed on to the car sharing service.

The end-user that wants to make use of car sharing service, must indicate to car sharing service that it is looking for a ride, and indicate its destination.

#### **2.1.3.6 Normal Flow**

1. Vehicle driver (owner) indicates that it is willing to provide the car sharing service.
2. Vehicle sends its current location, destination, number of available places and maybe other conditions (such as dogs accepted or not, luggage accepted or not) to the IoT platform.

3. Parking collect points/parking sends information to the IoT platform on the available vehicles on each known collect points/parking.
4. The IoT platform hosts the collected data from abovementioned sources, and upon request it will send it to AS where car sharing application (Car Sharing App) is running. Car sharing App is subscribed to the IoT data from all participants in traffic in urban area.
5. End-user looking for a ride sends request to car sharing service for car sharing with (optimal arrival or departure time and) destination.
6. Upon verification of request, CSS may request additional info from end-user (depending on conditions set by vehicle driver). If all criteria are met, CSS matches end-user to vehicle and send it location for pick-up to the IoT platform.
7. Processed information from App is sent back to IoT platform, and is made available to all Car sharing App subscribed participants in traffic.
8. Each participant in traffic is responsible for interpretation and action based on received App data.

### 2.1.3.7 Alternative Flow

None

### 2.1.3.8 Post-conditions

Vehicle stays in car sharing mode until the car sharing provider or vehicle owner decide that the vehicle cannot support the car sharing service anymore.

### 2.1.3.9 High Level Illustration

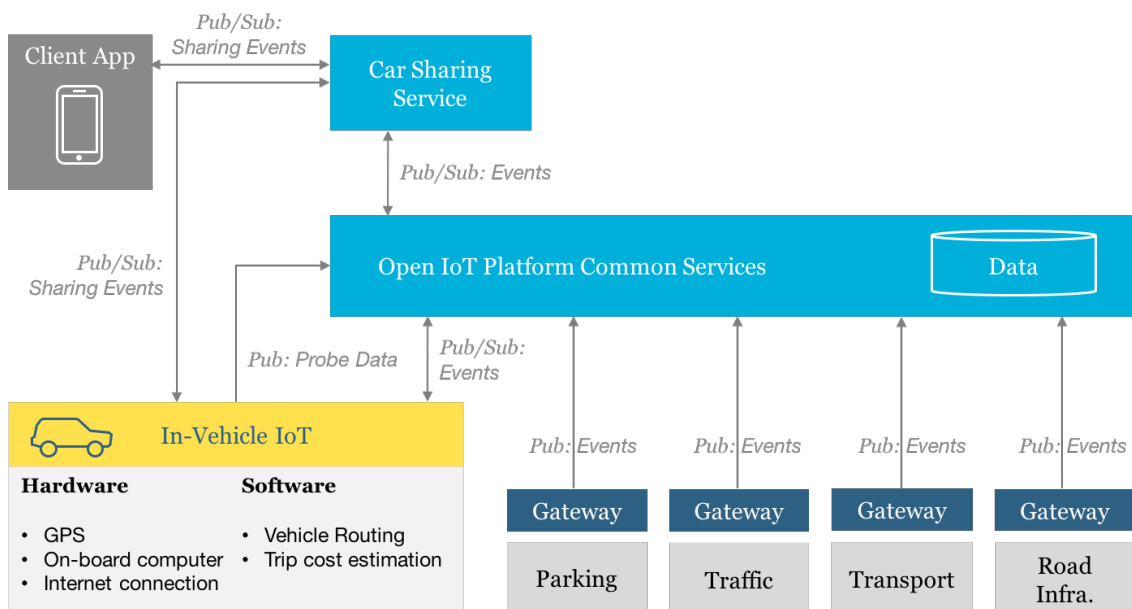

Figure 2-5: Example of IoT data streams and corresponding communication networks, based on [EC H2020 AUTOPILOT project](#)

### 2.1.3.10 Potential Requirements

Car sharing can be divided into two key components. One component focuses on the process of autonomous driving, and the other one is responsible to match the vehicles and their destinations to the potential customers (co-passengers).

The car sharing service is collecting requests for car sharing / co-riding from end-users (potential passengers) which includes their locations, arrival or departure times, and their destinations. Based on the pool of available vehicles, the car sharing service matches them to potential passengers. The vehicle which is matched to a particular passenger will receive new waypoints, including the place/location where the new passenger should be picked up. Note that this information on distributing the pick-up location is considered not to be time critical.

### 2.1.3.11 Radio Specific requirements

In car sharing, the car sharing planning component (passenger locations, and their destinations) is considered not to be time critical. The autonomous driving component is the one which is critical and is therefore imposing performance requirements on the underlying communication network.

Autonomous driving is dependent on the timely information received from other participants in the traffic. As discussed in Section 2.1.1.11, it is important to note that in the EC H2020 AUTOPILOT project, it is considered that an autonomously driving vehicle will be able to autonomously operate and drive even if this vehicle is not communicating with external sensors and sources. In situations that the autonomously driving vehicle uses communication means and data generated by external sensors and sources, it can make better and more accurate decisions on how to act.

Current 5G promises on performance capabilities, see Table 1, are able to support the requirements imposed by both the car rebalancing use case components, which are the autonomous driving and the car sharing planning.

## 2.1.4 Highway Pilot

### 2.1.4.1 Description

It is expected that autonomous driving will radically reshape transport networks around the world by reducing congestion, fatalities and fuel consumption, and improving other driving conditions, in particular on highway environments. Moreover, it is expected that autonomous driving in highway environments will reduce costs in the line-haul trucking industry by (up to) 40%;

The Highway Pilot function automates highway driving, meaning that steering and speed adjustments are executed by the automated driving system. As the name of the function already implies, the Highway Pilot is intended for use on Highways only. The added-value of

this function is its ability to enhance drivers' and automated vehicles' awareness on potential road hazards on route and to assist them to adapt their driving accordingly.

Road hazards may refer to several events and situations, such as:

- emergency braking vehicles / slow vehicles;
- stationary vehicles (breakdowns or accidents);
- fast approaching emergency vehicles;
- traffic jams and queues;
- road works / route modifications;
- nearby presence of bicycles or pedestrians;
- fallen objects (from vehicle, trees);
- road defects (potholes, bumps, gravel);
- weather related road changes (puddles, ice);

Receiving anticipated warning information about such events is useful on all types of road environments, including a highway context; where vehicles move at high-speed require shortened reaction time.

Furthermore, anticipated warning information also benefits all modes of driving:

- In Manual Driving mode, thanks to experience, drivers learn to handle hazardous situations. However, a sudden action from a driver (ex: trajectory change, quick deceleration) may become another hazard for others.
- In Assisted Driving mode, which is more and more used on Highway roads, drivers considerably relax their attention on the road, hence increasing their response time when a hazard occurs.
- In Automated Driving mode, passengers depend on the detection of the vehicle's own sensors. The hazard must enter the sensors perception range and be identified as such before the vehicle reacts. If the hazard is hidden around the corner, the reaction may be abrupt. For passengers' comfort and acceptance of AD functions, it is a priority that AD driving is as smooth as possible.

Finally, not all hazards will trigger pre-emptive actions from drivers and vehicles. For example, near missed potholes and slippery surfaces may go unnoticed and be noticed too late.

#### **2.1.4.2 Source**

[EC H2020 AUTOPILOT project](#)

#### **2.1.4.3 Roles and Actors**

- Vehicle owner / driver / passenger in the vehicle: Profits from the Highway Pilot service by decreasing the probability of vehicle damage/accidents in the highway environment and at the same time reducing the vehicle journey time when the road traffic jams on the highway are minimized or eliminated.

- IoT platform provider: It operates an IoT platform which is collecting data from vehicles, parking spots, parking entrances and exits, other participants in traffic present at the parking, and on the way to/from parking (such as pedestrians, cyclists), from surrounding roads and from surrounding associated infrastructure (such as traffic lights, cameras). Necessary information/data is provided to any devices that are subscribed to the IoT platform.
- Highway Pilot service provider: Party that is providing Highway Pilot service which runs on AS. Highway Pilot App connects to the IoT platform, and from there it collects relevant data needed to run an ADApp - for example LDM.
- Communication Network supplier/provider/operator: Supplies and/or provides and facilitates connectivity between vehicles, roads and associated infrastructure. This covers both wireless (for example LTE, LTE-V2X, ITS-G5 and WAVE) and fixed connections. The Network supports receiving requests for data transfers with required latency and with required packet losses. It is not expected or mandated that single network operator provides all of connectivity.
- IoT Devices Manufacturer: Manufactures IoT devices that are embedded in vehicles, roads and associated infrastructure, parking garage /terrain, traffic lights, as well as in devices used by other participants in traffic (pedestrians, cyclists). Each IoT device collects and sends data to IoT platform, and can receive data from platform.

#### **2.1.4.4 Pre-conditions**

The vehicle supports autonomous driving - meaning that it is capable of autonomously driving, also transmitting and receiving data from other vehicles, road and other infrastructure, other participants in traffic (such as pedestrians, cyclists).

#### **2.1.4.5 Triggers**

Highway pilot is activated automatically, when vehicle is driving on the highway, which can be determined in different ways (such as the location on the map).

#### **2.1.4.6 Normal Flow**

1. Vehicle detects that it is on the highway, and starts collecting data on obstacles on the road and damage (such as potholes, cracks) in the road surface. This information is sent to the IoT platform.
2. IoT in vehicle platform: is connected to the IoT open platform and to other IoT devices, also manages the LDM which contains all vehicles in vicinity and their current state (such as speed, acceleration / deceleration, changing lanes) and other traffic information like traffic light status or VRUs position.
3. 3rd party service: collects information from the highway environment about the road network and topology and about any obstacles on the road and damage (such as potholes, cracks) in the road surface and sends it to the IoT platform.
4. The IoT platform hosts the collected data from abovementioned sources, and upon request it will send it to AS where Highway Pilot application (Highway Pilot App) is

running. Highway Pilot App is subscribed to the IoT data from all participants in traffic in urban area.

5. Processed information from Highway Pilot App is sent back to IoT platform, and is made available to all the Highway Pilot App subscribed participants in traffic.
6. Each participant in traffic is responsible for interpretation and action based on received Highway Pilot App data.

#### 2.1.4.7 Alternative Flow

None

#### 2.1.4.8 Post-conditions

Vehicle stays in highway pilot mode until it leaves highway, which can be determined by e.g., vehicle's location.

#### 2.1.4.9 High Level Illustration

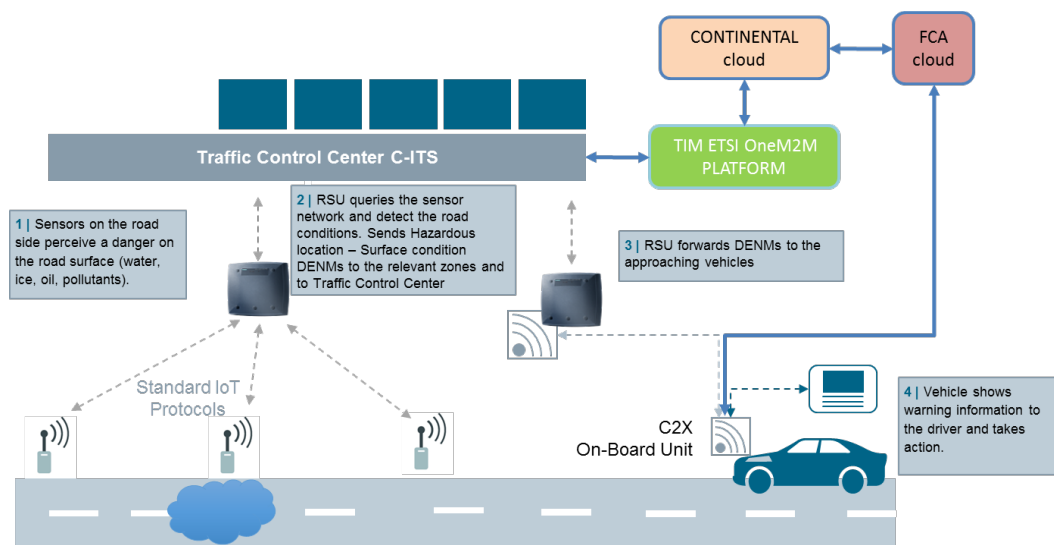

Figure 2-6: Example of IoT data streams and corresponding communication networks, based on [EC H2020 AUTOPILOT project](#)

#### 2.1.4.10 Potential Requirements

The Highway pilot use case can be divided into two key components. One component focuses on the process of autonomous driving, and the other one is responsible to detect obstacles on the road and to inform the vehicle to adapt its driving behaviour accordingly.

Obstacles of (or in) road surface can be detected by different sensors in vehicle. That can be accomplished by detecting activation of ABS sensors in absence of braking which can indicate a piece of ice or mud (or something else slippery), or by other means such as LiDAR, RADAR.

The collected information can be sent to other vehicles, most likely via a central platform which will collect data on detected obstacles from vehicles, and which can share that information with other vehicles approaching that particular spot on the road, and which can then adjust their driving accordingly.

#### 2.1.4.11 Radio Specific requirements

The Highway Pilot components: (1) detection of obstacles on the road and (2) sharing this information to vehicles to adapt their driving behaviour on the road accordingly, are considered not to be time critical. The autonomous driving component is the one which is critical, and is therefore imposing performance requirements on the underlying communication network.

Autonomous driving is dependent on the timely information received from other participants in the traffic. As discussed in Section 2.1.1.11, it is important to note that in the EC H2020 AUTOPILOT project, it is considered that an autonomously driving vehicle will be able to autonomously operate and drive even if this vehicle is not communicating with external sensors and sources. In situations that the autonomously driving vehicle uses communication means and data generated by external sensors and sources, it can make better and more accurate decisions on how to act.

Current 5G promises on performance capabilities, see Table 1, are able to support the requirements imposed by both the highway pilot use case components, which are (1) the autonomous driving and (2) the detection of obstacles on the road and sharing this information to vehicles to adapt their driving behaviour on the road accordingly.

### 2.1.5 Platooning

#### 2.1.5.1 Description

Platooning, see Figure 2-7 and Figure 2-8, is a use case where a vehicle is automatically following another vehicle at a relatively close distance. Driving in a platoon requires vehicles to use inter-vehicle communications to anticipate timely on manoeuvres of other vehicles in the platoon.



Figure 2-7: Platooning vehicles on public road, lead vehicle has driver





**Figure 2-8: Platooning trucks on public road, lead vehicle has driver**

Several aims and motivations for vehicular platooning exist, such as: (1) improvement of traffic throughput and homogeneity, (2) enhancement of traffic safety due to small speed variations and relative low impact velocities in collisions, and (3) reduction of fuel consumption and emissions due to lowering the air drag. These objectives can to a certain extent already be achieved by non-automated driving systems (i.e. human driver monitors the environment and may execute e.g. the steering task), although a higher level of automation is considered to contribute in a positive way. Automated driving (system performs all aspects of the dynamic driving task) can offer additional benefits in terms of comfort (relieving the driver from the driving task) and efficiency (no driver required in vehicles).

The following vehicles have automated steering and distance control to the vehicle ahead, and the control is supported by advanced Vehicle to Vehicle (V2V) communication extended with additional IoT data. In addition to driving in a platoon, forming of the platoon is also a challenging task.

Note that for practical purposes we will consider a platoon as logical entity which is extended (elongated) virtual vehicle.

#### **2.1.5.2 Source**

[EC H2020 AUTOPILOT project](#)

#### **2.1.5.3 Roles and Actors**

- Vehicle owner / driver / passenger in the vehicle: Profits from the Platooning service by enhancing traffic safety for vehicle driver and passenger, due to small speed variations and relative low impact velocities in collisions, and as well reduction of fuel consumption and emissions due to lowering the air drag.
- IoT platform provider: It operates an IoT platform which is collecting data from vehicles, roads, other participants in traffic present, and from surrounding associated infrastructure (such as traffic lights, cameras). Necessary information/data is provided to any devices that are subscribed to the IoT platform.
- Platooning service provider: Party that is providing Platooning Service (PS) which runs in cloud. It does authentication of vehicles that want to make use of platooning,

collects info on currently running platoons, and provides 'rendezvous' info needed for vehicle to meet platoon. Note that this service will (very likely) make use of route planning function, not covered here.

- Platooning manager provider: Party that is providing Platooning Service (PS) which runs on Multi-access Edge Computing (MEC) node. Note that it is possible to have this function also running on cloud.
- Platooning function provider: Platooning function runs in vehicles and is responsible for maintaining the position of the vehicle in the platoon (distance to other vehicles, follow trajectory of lead vehicle), as long as the vehicle is a member of the platoon.
- Communication Network supplier/provider/operator: Supplies and/or provides and facilitates connectivity between vehicles, roads and associated infrastructure. This covers both wireless (for example LTE, LTE-V2X, ITS-G5 and WAVE) and fixed connections. The Network supports receiving requests for data transfers with required latency and with required packet losses. It is not expected or mandated that a single network operator provides the whole end-to-end connectivity.
- IoT Devices manufacturer: Manufactures IoT devices that are embedded in vehicles, roads and associated infrastructure, parking garage /terrain, traffic lights, as well as in devices used by other participants in traffic (pedestrians, cyclists). Each IoT device collects and sends data to IoT platform, and can receive data from platform.

#### **2.1.5.4 Pre-conditions**

The vehicle supports autonomous driving as well as platooning - meaning that it is capable of autonomously driving, also transmitting and receiving data from other vehicles, road and other infrastructure, other participants in traffic (such as pedestrians, cyclists).

#### **2.1.5.5 Triggers**

Platooning is activated by vehicle driver. Driver can start this function either before starting a trip, by indicating where it needs to go, and its current location is taken as starting point, or it can do it during the (started) driving session.

The PS will match this user (and its vehicle) to one of existing (or yet forming) platoons. After calculating the route for this user, the platooning service will provide this data so vehicle will rendezvous with chosen platoon.

#### **2.1.5.6 Normal Flow**

Three phases in platooning are distinguished:

1. Finding platoon going in preferred direction: This is done by platooning service, which runs in cloud, and has overview or large swath of particular country, and view on all platoons (their origin, current location and state, and destination).
2. Joining or leaving the platoon – happens when vehicle comes into vicinity of chosen platoon.
3. Driving in the platoon.

#### **2.1.5.6.1 Normal Flow 1: Finding platoon - Platooning service**

1. User contacts the PS, authenticates itself and states its own destination and leave / arrival time.
2. PS searches all platoons that travel to the preferred destination, verify their leaving /arrival times, and matches user (and its vehicle) to one platoon that fulfils the user request.
3. PS collects current platoon's state via IoT platform and uses that info to plan a route for user's vehicle so it can meet / join the platoon.
4. PS informs user's vehicle on chosen route and rendezvous point.
5. Vehicle starts riding to the rendezvous point.

#### **2.1.5.6.2 Normal Flow 2: Joining the platoon - Platooning manager**

The condition is that the vehicle that wants to join a platoon is in vicinity of the platoon, but it has not yet joined the platoon.

1. Platoon manager keeps track of the platoon and the vehicle that wants to join.
2. When the distance between those two is small enough and it is safe to perform the manoeuvre of joining the platoon (enough space, no traffic lights in vicinity, no other participants), it will instruct (1) the leading vehicle of the platoon, (2) trailing vehicle of the platoon and (3) the vehicle wishing to join that they can start process of joining.
3. The signalling during the joining process uses V2V communication.

#### **2.1.5.6.3 Normal Flow 3: Driving - Platooning**

1. Vehicle receives messages from other vehicles in the platoon and acts accordingly.

#### **2.1.5.7 Alternative Flow**

None

#### **2.1.5.8 Post-conditions**

Vehicle stays in the platooning mode until:

1. It arrives at destination, or comes close to it, when it leaves platoon and drives the rest of the way autonomously to the destination.
2. It can be triggered by user to leave a platoon – and continue autonomously
3. It receives information from the platooning service that it can / should leave the current platoon and join other platoon. An example is the multi-hop platooning, where a vehicle member of a platoon, say platoon 1, which follows a certain route, will need to leave at a calculated position and time the platoon 1 and join another platoon, say platoon 2, which will follow a different route to a different destination than platoon 1. During the short time that the vehicle needs to switch between the two platoons, the vehicle can drive autonomously.

### 2.1.5.9 High Level Illustration

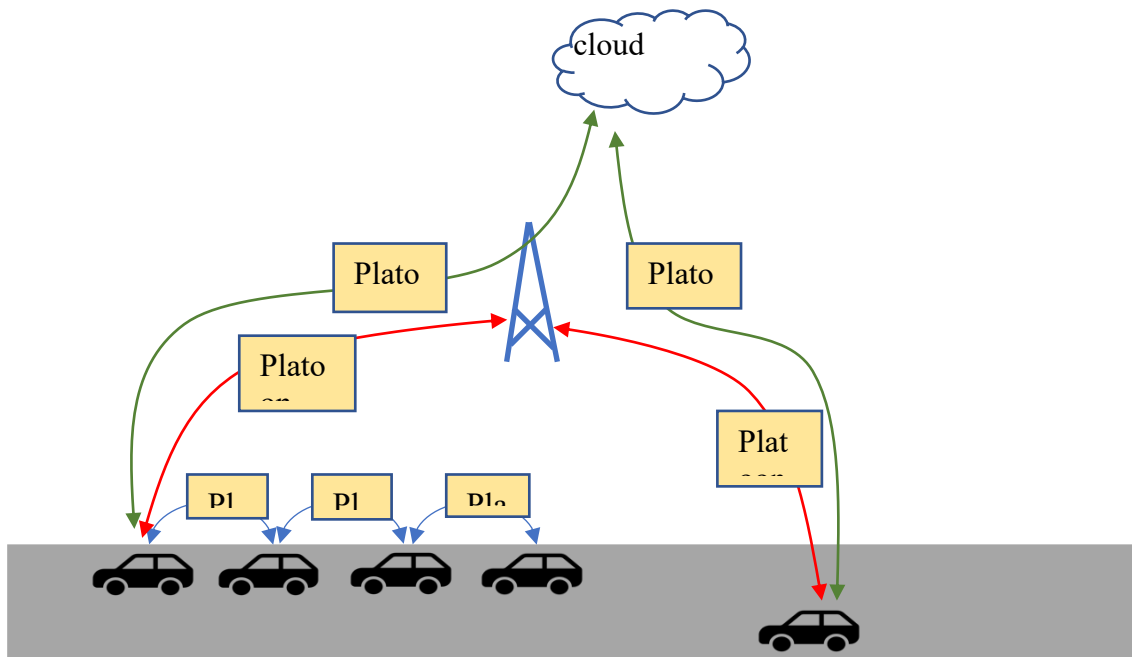

Figure 2-9: Data flows in platooning, based on [EC H2020 AUTOPILOT project](#)

### 2.1.5.10 Potential Requirements

Platooning is a time critical cooperative activity, and vehicles are continuously engaged with the creation and maintenance of the dynamic driving behaviour world models. The Platooning use case can be divided into two key components. One component focuses on the process of autonomous driving, and the other one is responsible to create and maintain the dynamic driving behaviour world model, which defines the autonomously driving behaviour of the vehicle.

Besides, the actual autonomous driving component there is also another time critical component to continuously update the vehicle's dynamic driving behaviour world models.

When driving in a platoon, the actual distance between vehicles driving in the platoon depends on a number of factors like vehicle's speed and state of roads. The higher the speed – the longer will be the distance between vehicles. The slower the processing of data in vehicle (longer time needed) – the more distance is needed between vehicles. The unit that is used to measure the distance between two vehicles is denoted as time headway and represents the time between vehicles in a transit system. The minimum time headway is the shortest such distance or time achievable by a system without a reduction in the speed of vehicles.

One of the motivations for driving in a platoon is to increase the vehicle road traffic flow by decreasing the minimum time headway. Driving in a platoon decreases as well (1) the total processing time of a vehicle traffic participant that needs to send information on its performed driving actions and (2) the time that other vehicle traffic participants will process that message and act accordingly.

### 2.1.5.11 Radio Specific requirements

Autonomous driving is dependent on the timely information received from other participants in the traffic. As discussed in Section 2.1.1.11, it is important to note that in the EC H2020 AUTOPILOT project, it is considered that an autonomously driving vehicle will be able to autonomously operate and drive even if this vehicle is not communicating with external sensors and sources. In situations that the autonomously driving vehicle uses communication means and data generated by external sensors and sources, it can make better and more accurate decisions on how to act.

Current 5G promises on performance capabilities, see Table 1, are able to support the requirements imposed by both the Platooning use case components, which are (1) the autonomous driving and (2) the creation and maintenance of the dynamic driving behaviour world model, which defines the autonomously driving behaviour of the vehicle.

## 2.1.6 Urban Driving

### 2.1.6.1 Description

Autonomous vehicles have the potential to remove human error and reduce instances of accidents caused by driver error, drunk driving or distracted drivers, in particular in Urban Driving environments.

Urban Driving, see Figure 2-10, assisted by IoT has the main objective to support Connected and Automated Driving (CAD) functions through the extension of the Electronic Horizon of an automated vehicle. Thus, the vehicle can process data from external sources which enrich those provided by its own sensors (such as Camera, LIDAR, and Radar). The type of relevant information that automated vehicles may access as IoT elements, concerns:

- Traffic lights at intersections.
- Information from infrastructure cameras (such as pedestrian, bicycle, obstacle presence).
- Information from VRU.
- Information from other vehicles captured by their own sensors and shared as IoT elements.

Taking this type of information into account, the CAD systems will adapt their behaviour according to the additional environmental information, available through their connection to an onboard IoT platform.



Figure 2-10: Urban driving scenario, based on [EC H2020 AUTOPILOT project](#)

#### 2.1.6.2 Source

[EC H2020 AUTOPILOT project](#)

#### 2.1.6.3 Roles and Actors

- Vehicle owner / driver / passenger in the vehicle: Profits from the Urban Driving service by decreasing probability of vehicle damage/accidents in the urban environment and at the same time reducing the vehicle journey time when the road traffic jams on the urban roads are minimized or eliminated.
- IoT platform provider: It operates an IoT platform which is collecting data from urban traffic data sources such as: (1) Traffic lights at intersections, (2) Information from infrastructure cameras (such as pedestrian, bicycle, obstacle presence), (3) Information from VRUs, (4) Information from other vehicles captured by their own sensors and shared as IoT elements. Necessary information/data is provided to any devices that are subscribed to the IoT platform.
- Urban Driving service provider: Party that is providing Urban Driving Service which runs on AS. Urban Driving App connects to the IoT platform, and from there it collects relevant data needed to run an ADApp - for example LDM.
- Urban Driving manager provider: Party that is providing Urban Driving Service which runs on AS. Urban Driving App connects to the IoT platform, and from there it collects relevant data needed to run an ADApp - for example LDM.
- Communication Network supplier/provider/operator: Supplies and/or provides and facilitates connectivity between vehicles, roads and associated infrastructure. This covers both wireless (for example LTE, LTE-V2X, ITS-G5 and WAVE) and fixed connections. The Network supports receiving requests for data transfers with required latency and with required packet losses. It is not expected or mandated that single network operator provides all of connectivity.
- IoT Devices manufacturer: Manufacturer provides IoT devices are embedded in vehicles, roads and associated infrastructure, parking garage /terrain, traffic lights, as

well as in devices used by other participants in traffic (such as pedestrians, cyclists). Each IoT device collects and sends data to IoT platform, and can receive data from platform.

#### **2.1.6.4 Pre-conditions**

The vehicle supports autonomous driving - meaning that it is capable of autonomously driving, also transmitting and receiving data from other vehicles, road and other infrastructure, other participants in traffic (such as pedestrians, cyclists).

#### **2.1.6.5 Triggers**

Urban Driving is activated automatically, when vehicle is driving on the urban environment, which can be determined in different ways (location on the map, for example).

#### **2.1.6.6 Normal Flow**

1. Traffic light: information about the traffic light status and time to change is sent to the IoT platform.
2. Road smart camera: information about pedestrian detection is sent to IoT platform.
3. Traffic sensors or TMC (Traffic Management Center): information about 3 possible events: traffic jam, accident and road work warning are sent to the IoT platform.
4. VRUs: information for pedestrian detection is sent to the IoT platform.
5. 3rd party service: gives information about the road network and topology.
6. IoT in vehicle platform: is connected to the IoT open platform and to other IoT devices, also manages the LDM which contains all vehicles in vicinity and their current state (speed, acceleration / deceleration, changing lanes etc.) and other traffic information like traffic light status or VRUs position.
7. The IoT platform hosts the collected data from abovementioned sources, and upon request it will send it to AS where Urban Driving application (Urban Driving App) is running. Urban Driving App is subscribed to the IoT data from all participants in traffic in urban area.
8. Processed information from Urban Driving App is sent back to IoT platform, and is made available to all Urban Driving App subscribed participants in traffic.
9. Each participant in traffic is responsible for interpretation and action based on received Urban Driving App data.

#### **2.1.6.7 Alternative Flow**

None

#### **2.1.6.8 Post-conditions**

Vehicle stays in urban driving mode until it leaves the urban road environment, which can be determined by e.g., the vehicle's location.

### 2.1.6.9 High Level Illustration

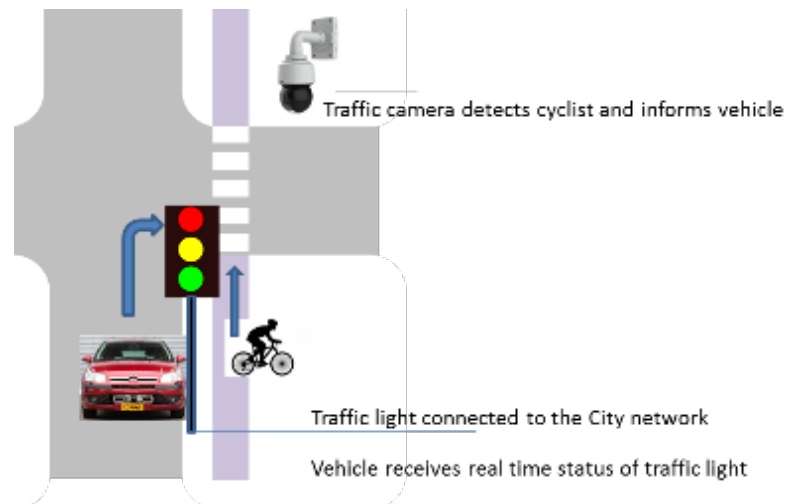

Figure 2-11: Example of IoT data streams and corresponding communication networks, based on EC H2020 AUTOPILOT project

### 2.1.6.10 Potential Requirements

The urban driving use case can be divided into two key components. One component focuses on the process of autonomous driving, and the other one is responsible to (1) collect data from external sources and (2) use this collected data by the vehicle's CAD system to adapt vehicle's driving behaviour according to the additional environmental information.

One of the major challenges in urban driving is the large number of participants in traffic. The vehicle speed is not really a challenge, which is limited (50 km/h, or 30 km/h in residential areas). Due to the higher density of vehicle traffic participants, the distances between them are in average shorter than other environments, and the corresponding time headways are smaller. For example, when vehicle is driving with 50 km/h, it covers almost 14 meters per second. If for example, data is being sent with frequency of 10Hz, the vehicles will send data every 100ms. Due to the higher density of vehicle traffic participants, each vehicle will receive data that is sent data by a large number of vehicles. This fact will (1) increase the throughput of data that each vehicle needs to process, (2) will require larger transmitting and receiving buffers and (3) will decrease the available time that each vehicle needs to activate actuators (brakes for example).

### 2.1.6.11 Radio Specific requirements

Autonomous driving is dependent on the timely information received from other participants in the traffic. As discussed in Section 2.1.1.11, it is important to note that in the EC H2020 AUTOPILOT project, it is considered that an autonomously driving vehicle will be able to autonomously operate and drive even if this vehicle is not communicating with external sensors and sources. In situations that the autonomously driving vehicle uses communication means and data generated by external sensors and sources, it can make better and more accurate decisions on how to act.



Current 5G promises on performance capabilities, see Table 1, are able to support the requirements imposed by the urban driving use case components, which are (1) the autonomous driving, to (2) collect data from external sources and (3) use this collected data by the vehicle's CAD system to adapt vehicle's driving behaviour according to the additional environmental information. However, it is important to note that the urban driving use case will require from vehicles to maintain larger transmitting and receiving buffers and as well requires a shorter processing time to activate actuators (brakes for example).

## 2.1.7 Vehicle Monitoring

### 2.1.7.1 Description

Data gathering from vehicles is currently done in commercial solutions using cellular networks, although the research direction for this type of communications focus on Cooperative Intelligent Transportation Systems (C-ITS) solutions including On-Board Units (OBU) with more complex networking solutions. For example, including hybrid schemes alternating IEEE 802.11p with cellular technologies, such as LTE, LTE-V2X. This is, however, a clear case where the IoT paradigm comes into play, given that the vehicle could be considered a moving sensor or, even more, a moving smart environment composed of a set of them. In this sense, IoT communication technologies in the segment of Low-Power Wide Area Networks (LP-WAN) could be considered for these vehicular scenarios.

LP-WAN technologies would allow the access to on-board sensor information over long ranges, at the same time battery consumption of devices installed in non-common vehicles, such as bikes or motorbikes, is maintained low. Technologies such as SigFox and LoRa can be complemented with those in line with 5G trend, such as Narrowband-IoT (NB-IoT) or Massive Machine-Type Communications (mMTC). NB-IoT is the first step of 3GPP specifications to cover the LP-WAN segment, while mMTC will be a fundamental building block of 5G in this particular area of cellular support for IoT.

Vehicle monitoring using IoT cellular technologies could be especially useful, for instance, in urban mobility scenarios, where cars, bikes, mopeds or even skates could be monitored to adapt traffic lights, recommend green tracks, avoid traffic jams, suggest secure riding areas, or speed-up the adoption of healthy transport habits.

### 2.1.7.2 Source

IoT projects that were accomplished by AIOTI members and are described in the below listed publications:

- S. Barrachina-Munoz, B. Bellalta, T. Adame, and A. Bel. Multi-hop communication in the uplink for LP-WANs. *Computer Networks*, 123:153 – 168, 2017.
- Ramon Sanchez-Iborra, Jesús Sánchez-Gómez, José Santa, Pedro J. Fernández, Antonio F. Skarmeta. Integrating LP-WAN Communications within the Vehicular Ecosystem. The 2017 International Symposium on Mobile Internet Security (Mobisec 2017). Jeju Island, Republic of Korea, 2017.

- Ramon Sanchez-Iborra, Jesús Sánchez-Gómez, José Santa, Pedro J. Fernández, Antonio F. Skarmeta. IPv6 Communications over LoRa for Future IoV Services. 4th IEEE World Forum on Internet of Things (WF-IoT 2018). Singapore, Singapore, 2018.

#### 2.1.7.3 Roles and Actors

The following list of actors is identified in the vehicle monitoring use case when applying cellular IoT technologies:

- Vehicle: common cars, vans, trucks, bikes, motorbikes, mopeds, skates, and any other kind of vehicles, with especial implication of those involved in urban mobility scenarios.
- Telecomm operator: providing the IoT network access.
- Service provider: in charge of feeding their applications to provide services to final users.
- Final user: who uses services powered by monitoring data probably processed?

#### 2.1.7.4 Pre-conditions

The next preconditions are identified:

- The vehicle should be equipped with a proper OBU that allows monitoring its status.
- The telecom operator should have deployed the needed network infrastructure to offer connectivity.
- The OBU is provided with sensors (e.g., Global Positioning System (GPS)) or with access to on-board sensors where to gather data (e.g. diagnosis port).

#### 2.1.7.5 Triggers

No special triggers are identified, although, with the aim of save communication resources, monitoring of specific parameters could be only performed once significant changes are perceived or some time has elapsed, for instance.

#### 2.1.7.6 Normal Flow

Data is generated or accessed in a regular basis by the OBU, which uses the cellular LP-WAN link to transmit it to a remote server through the operator's network. Usually the remote server will be a cloud service. After the data is processed, a service in the same node or a different one is fed with it to finally create a value-added service for users. This service could be accessed through an App or a web interface, for instance, from regular or mobile devices with Internet access.

#### 2.1.7.7 Alternative Flow

None

#### 2.1.7.8 Post-conditions

The final user is informed of specific events in a particular scenario, such as pollution areas, secure riding tracks, non-congested roads, or vehicle faults detected or predicted.

### 2.1.7.9 High Level Illustration

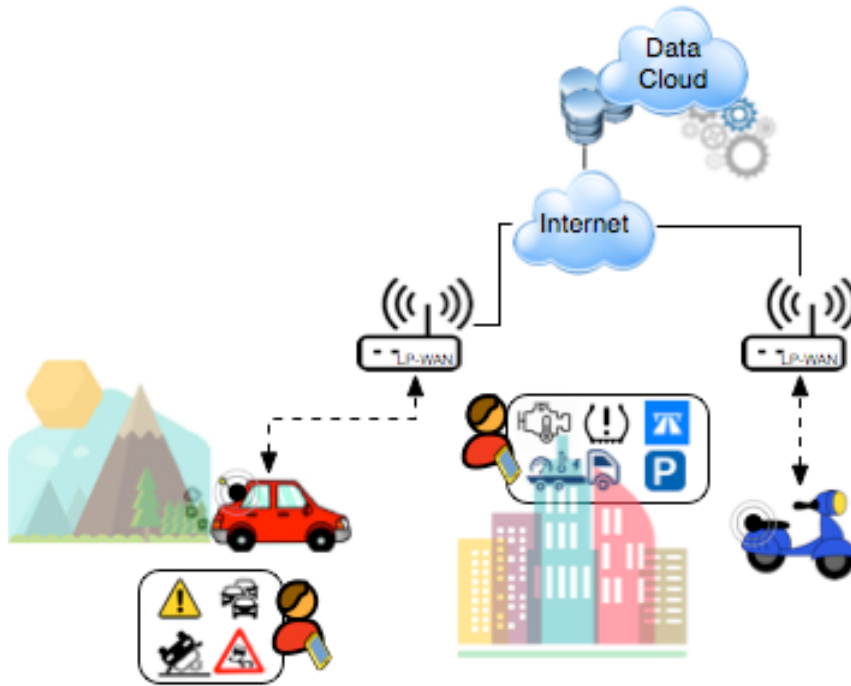

Figure 2-12: Vehicle Monitoring - High level illustration

### 2.1.7.10 Potential Requirements

The following non-functional requirements are identified:

- The service should accommodate to cover vehicles within a limited area, considering challenges scenarios such as the urban ones, and it should scale to many communication units under particular circumstances, such as festivals or rush hours.
- The 3GPP standard deployment in Europe, at least, should support the normal operation of the monitoring operation in a cross-border fashion.
- Privacy issues should be considered to avoid tracking risks, among others.

### 2.1.7.11 Radio Specific requirements

Table 2: Vehicle Monitoring radio specific requirements

Requirement	Explicit 5G Promises, see [1]	Vehicle requirements	Monitoring
Real-time Latency	5 ms (e2e)	1 s	
Real-time Jitter	-	Tolerant	
Bandwidth	Peak data 10 Gbps	100 kbps	

<b>Time period of information loss during failures</b>	-	none (seamless failover)
<b>Availability / coverage</b>	-	Ubiquitous
<b>Range (distance between communication neighbours)</b>	-	> 1 Km (long-range)
<b>Reliability</b>	99.999%	70%
<b>Mobility</b>	500km/h	200 Km/h
<b>Outdoor terminal location accuracy</b>	<1m	<10m
<b>Multi-tenant support</b>	yes	Yes
<b>Non-standard operating conditions</b>	energy reduction by 10	Possible powered device with >1 day lifetime Vibrations in a car
<b>Harsh environment (weather)</b>		Subject to in-vehicle temperature
<b>Ease of use</b>	-	Plug and Play device (just like a sensor)
<b>Communication service approach</b>		yes
<b>SLA Tooling</b>	-	Service Level Agreement (SLA) monitoring
<b>Service deployment time</b>	90min	days
<b>Private 5G infrastructure</b>	-	no
<b>Scalability: Number of devices per km2</b>	1.000.000	100
<b>Globally harmonized definition of Service Qualities</b>	-	-
<b>Technology availability</b>	-	> 15 years

<b>Globally simplified certification of ICT components</b>	-	Yes
<b>Assured Guarantees</b>	-	Relaxed

#### **2.1.7.11.1 Radio Coverage**

- Radio cell range
  - Long range (> 1 Km) under Line of Sight (LOS) and Non Line of Sight (NoLOS) conditions.
- Does the radio link crosses public spaces? Or is it constrained to indoor or customer premises?
  - The radio link crosses public spaces mainly outdoors, given the monitoring features for vehicles.
- Is Multicell required?
  - It is not required, but it is supposed that in urban settings multicell will be present to improve the network capacity.
- Is handover required? Seamless? Tolerable impact in delay and jitter?
  - There are not special handover requirements, given that the loss of some packets in a monitoring service could be supported. The same applies to delay and jitter.
- Mobility: maximum relative speed of UE/FP peers
  - Low to high mobility, considering potential vehicle types and mobility patterns. Maximum speeds of 200 Km/h should be supported or highway scenarios.
- Special coverage needs: i.e., maritime, aerial
  - No, only terrestrial.

#### **2.1.7.11.2 Bandwidth requirements**

- Peak data rate:
  - 100 Kbps.
- Average data rate
  - 10 Kbps.
- Is traffic packet mode or circuit mode?
  - Packet mode.

#### **2.1.7.11.3 URLLC requirements**

- Required Latency

- Usually one-way communication with latency tolerance up to 1 second.
- Required Reliability
  - 70% (tolerant to losses).
- Maximum tolerable jitter
  - 1 second (no especial jitter requirements).

#### **2.1.7.11.4 Radio regimens requirements**

- Desired and acceptable radio regimens
  - When possible, it is preferred licence – public mobile, in order to improve interoperability support and wide coverage of the service.

#### **2.1.7.11.5 Other requirements**

- UE power consumption
- Rechargeable or primary battery?
  - When possible, a rechargeable battery should be used for the system if the communication unit is mounted in a two-wheeled vehicle.
- Acceptable battery life
  - At least enough to cover a trip (e.g. one day).
- Is terminal location required? Location accuracy?
  - Yes. Accuracy below 10 meters would be highly beneficial for the kind of services to be fed by the monitoring system.

## 2.2 Smart City

### 2.2.1 Public Warning System in critical infrastructures

#### 2.2.1.1 Description

Our main intention is to provide efficient, standard and secure communication of emergency to a broad name of stakeholders related to the critical infrastructures (e.g. vicinity/citizens, emergency bodies, governmental bodies, civil protection organizations and/or other related critical infrastructure -cascading effects-). To specifically build an effective emergency communication, secure communication protocols with the critical infrastructure (like 5G) are needed. Moreover, protocols with the emergency stakeholders and vicinity/citizens (e.g. Global System for Mobile communications (GSM), Universal Mobile Telecommunications System (UMTS), TCP/IP, 3GPP) should be performed. The proposed public warning system that is presented in this section considers the combination of Cell Broadcasting Systems and Web-Based services such as Open Geospatial Consortium (OGC) (Service Alerting System (SAS), Sensor Observation Service and Web, Web processing Service, etc.). This system broadcasts the emergencies to geographic areas using a combination of traditional (radio, phone) and innovative communications (RSS, Social Media, Extensible Markup Language (XML), JSON). Moreover, the possibility to include Reverse 112 (R112) is explored as another innovative emergency communication, which is currently not widely deployed in Europe.

#### 2.2.1.2 Source

[STOP-IT H2020 European project](#)

#### 2.2.1.3 Roles and Actors

- **Citizens & Vicinity.** People who lives (near) a critical infrastructure and needs to be protected or informed about potential major disaster incident risks that could affect their lives.
- **Critical Infrastructure.** Central element source of vulnerabilities that can become real risks (natural or cyber risks).
- **Emergency Bodies.** Stakeholders dedicated to minimizing the effects of the risks once them happens (such as hospitals, firemen).
- **Governmental bodies.** Stakeholders required to organize the society and provide insights at higher level.
- **Civil Protection Organization.** Stakeholders dedicated to mobilizing and organize the citizens in emergency situations.

#### 2.2.1.4 Pre-conditions

Main pre-condition is to live a potential risk in the critical infrastructure (such as water, energy, transport) that could create damage to other critical infrastructure or the society (such as critical infrastructure attacks, floorings, earthquakes).

### 2.2.1.5 Triggers

The triggers used in this use-case are: (1) the major disaster incident happens, or (2) the major disaster incident is detected by the critical infrastructure before occurring.

### 2.2.1.6 Normal Flow

Commonly, the steps are the follows:

1. Critical infrastructure systems (such as IoT systems, Supervisory Control and Data Acquisitions (SCADAs), informational systems, and risk management systems) are continuing monitoring the critical infrastructure until a potential risk is detected or a major disaster incident occurs.
2. At this moment, the critical infrastructure communicates with other related critical infrastructures that could be affected by these risks (transport, energy, water, etc.).
3. In parallel, the critical infrastructure that is suffering from the incident, establishes the contact with emergency bodies (in case of required) and civil protection bodies.
4. Once the risks have been minimized or solved, the critical infrastructure informs the citizens, vicinity and governmental bodies about the incidents that happened.

### 2.2.1.7 Alternative Flow

None

### 2.2.1.8 Post-conditions

Once the risks have been minimized or solved, the critical infrastructure informs the citizens, vicinity and the governmental bodies about the disaster incidents that happened. Moreover, informative actions are established towards the vicinity and governmental bodies about the critical infrastructure situation.

### 2.2.1.9 High Level Illustration

### 2.2.1.10 Potential Requirements

#### Functional Requirements

- Real-time communication with the stakeholders in case of emergency.
- Reliable communication between the stakeholders.
- Scalable communication between systems to interconnects different critical infrastructures.
- Standard-based communication between critical infrastructure to align emergency information exchange with new and legacy systems.

#### Non-Functional Requirements

- Secure communication between the emergency bodies due to the information nature.



- Interoperability between communication protocols (linked also with the possibility to use standard communication protocols between the systems).

## **2.2.1.11 Radio Specific requirements**

### **2.2.1.11.1 Radio Coverage**

Long transmissions are required due to transmit the emergency messages to the neighbourhood and community (around 10-20km).

### **2.2.1.11.2 Bandwidth requirements**

- Peak data rate
- Average data rate
- Is traffic packet mode or circuit mode? If circuit mode, is isochronicity required?
  - The system needs to be prepared for working in public areas/spaces. Considering the transmission, WAN or GSM are needed with peak data rates of less than 70kbps.

### **2.2.1.11.3 URLLC requirements**

- Required Reliability
  - 99,99999%

### **2.2.1.11.4 Radio regimens requirements**

- Desired and acceptable radio regimens
  - Expected to use emergency radio bands

## 2.2.2 Unmanned Aerial Vehicles (UAV) as Multi-access Edge Computing (MEC) Nodes for Emergency Operations Support

### 2.2.2.1 Description

5G and Internet of Things will need to coexist and interoperate with each other. However, the adopted communication technologies and the actual requirements of the end-devices in both paradigms will be notably different. While 5G devices will make an intensive use of the network, in terms of throughput and volume of exchanged data, IoT end-nodes will require low bandwidth but high reliability and controlled energy-consumption for their communication tasks. Therefore, it is clear that gateways or access points with different Radio Access Technologies providing connectivity to different-nature end-nodes will be demanded shortly. Besides, following the MEC or fog paradigms, approaching processing or storage capabilities to the end-users will increase the performance of the system in terms of reduced latency and improved network efficiency. Up-to-date, these elements, i.e., communication gateways and processing nodes, have been located in fixed position hence, presenting a notable lack of flexibility for properly developing certain services. However, recent advancements in the design and use of Unmanned Aerial Vehicles (UAV) have turned these devices to a potential alternative for hosting communication, processing, and storage elements with the aim of offering next-generation services in situations where there is not a pre-existent communications infrastructure.

These features enable a plethora of novel services related with many actuation fields such as smart agriculture and farming, natural disaster monitoring, search and rescue, high-scale monitoring, etc. Concretely, the use case presented here focuses on using UAVs in emergency situations as support nodes for the rescue service, e.g., fire brigade, military units, etc. In the envisioned application, the UAVs are equipped with different communication and sensing technologies in order to provide novel services to the fire brigade that will help operational managers to make smart decisions by having a more complete information in real-time about the state of the managed event, e.g. fire extinction, rescue operation, etc. Thereby, a low-weight mini-computer is placed onboard the drone for providing multi-access communications to the fire brigade and enabling real-time aerial visualization of the scenario as well. Other sensors such as thermal or infrared are also considered for enriching the information provided to the management team.

### 2.2.2.2 Source

Based on IoT projects that were accomplished by AIOTI members; some of these IoT projects are described in the below listed publications:

- D. Carrillo and J. Seki, "Rural area deployment of internet of things connectivity: LTE and LoRaWAN case study," Proc. 2017 IEEE 24th Int. Congr. Electron. Electr. Eng. Comput. INTERCON 2017, 2017.
- N. H. Motlagh, M. Bagaa, and T. Taleb, "UAV-Based IoT Platform: A Crowd Surveillance Use Case," IEEE Commun. Mag., vol. 55, no. 2, pp. 128–134, 2017.

- S. Hayat, E. Yanmaz, and R. Muzaffar, "Survey on unmanned aerial vehicle networks for civil applications: a communications viewpoint," *IEEE Commun. Surv. Tutorials*, vol. PP, no. 99, pp. 1–1, 2016.
- E. Yanmaz, S. Yahyanejad, B. Rinner, H. Hellwagner, and C. Bettstetter, "Drone networks: Communications, coordination, and sensing," *Ad Hoc Networks*, vol. 68, pp. 1–15, 2018.
- Jawhar, N. Mohamed, J. Al-Jaroodi, D. P. Agrawal, and S. Zhang, "Communication and networking of UAV-based systems: Classification and associated architectures," *J. Netw. Comput. Appl.*, vol. 84, no. 31, pp. 93–108, 2017.

### 2.2.2.3 Roles and Actors

As aforementioned, the users for the proposed use case, are rescue services that will increase the accuracy and efficiency of their operations. The safety of these teams will be enhanced as well due to the constant monitoring of both, the conflictive scenario and the own rescue individuals. In general, all the public forces will take advantage of this architecture in events where aerial support provides clear advantages for managing the situation.

From the network operator perspective, 5G communications are envisioned to provide UAVs with high-speed and low-latency connectivity. In case of lack of 4G-LTE or 5G coverage, other broadband alternatives can be considered such as WiFi (IEEE 802.11) or Worldwide Interoperability for Microwave Access (WiMAX), i.e., IEEE 802.16. It is also proposed the use of Low Power Wide Area Network (LP-WAN) for low-bandwidth and very-long distance communications. In the case of these alternatives, a private third-party may be in charge of deploying and operating the temporary network hence making transparent its use for the end-users.

Considering the sensing and monitoring equipment on-board the UAV, multiple alternatives depending the situation can be adopted. As IoT controller, mini-computers with very low weight such as Raspberry Pi series or similar devices are a feasible alternative. Multiple sensors or cameras can be integrated within the system so IoT-device manufacturers are definitely involved in this process for providing equipment able to meet the challenging demands of the considered scenarios.

### 2.2.2.4 Pre-conditions

In order to provide UAVs with stable and reliable 5G communications, it is necessary to have an extensive cellular deployment covering large areas with 5G connectivity. In other case, temporary networks will be deployed. Note that the presented use-case should assume no pre-existent conditions for its successful development.

### 2.2.2.5 Triggers

The first trigger is the utility of the proposed use case. Public forces may be highly interested in the presented use case for managing disaster or critical situations:

- Rescue missions.

- Fire extinction.
- Individuals and fleet tracking.
- Accident-situation management.

The presented use case increases both the efficacy of the operations and the safety of the field team, so the utility and interest of potential users seem clear.

The technology needed for developing the current use case is already ready, with the exception of the upcoming 5G wide deployment. However, this is an important element for triggering this use case as it will provide very high-bandwidth and low-latency connectivity that will enable real-time services to the system managers.

#### 2.2.2.6 Normal Flow

It is envisioned that the UAV will provide real-time video to the management team, as well as other information gathered by the on-board sensors (thermal, infrared, pollution, etc.). With this multiple purpose platform, different services will be provided to the emergency service:

- Real-time video-surveillance of the situation.
- Tracking of the team in the field.
- High-accuracy conditions monitoring, such as:
  - Pollution levels.
  - Gasses composition.
  - Temperature.
- Fleet tracking and organization

This information need to be forwarded to the ground control station, where the operative managers make use of it. In order to establish a reliable and sufficient link (in terms of bandwidth and latency) some communication technology can be considered. Therefore, depending on the state of the pre-existent infrastructure, e.g., cellular communications, the UAV would be equipped with different communication alternatives. For broadband communications, in case of having accessible the cellular network, 4G-LTE and future 5G services are the perfect options due to the high bandwidth provided, and the long-range reached. However, in case of disaster events, where all the communication infrastructure is down, other options such as WiFi (IEEE 802.11) or WiMAX (IEEE 802.16) are good options for establishing UAV-to-UAV (U2U) or UAV-to-Ground (U2G) links. These links are fundamental for providing the operational team with the information retrieved by the onboard monitoring and sensing devices. In case of not having direct connectivity with the ground base station or the pre-existent infrastructure, U2U communications might be adopted for reaching these gateways.

Besides, LP-WAN communications are also considered in this use case for specific services. Due to the limited data-rate and bandwidth of these technologies, they are not intended for transmitted high-volumes of data but for specific tasks. One interesting application is

monitoring the position of field brigades and their individual components. In case of dense smoke or low-visibility area, e.g. forest or jungle scenarios, camera tracking is not enough for succeeding in this task. Thus, by using a GPS device integrated in the user-terminal, it could be able of periodically sending the current coordinate to the UAV by means of this long-range and highly reliable link. In addition, alert messages associated with specific events, e.g., down man, might be enabled as well.

#### 2.2.2.7 Alternative Flow

One of the most appreciated features of multi-access systems is their capability of switching to the most proper communication technology in case of the failure of one of them. Therefore, in a disaster situation in which the pre-existent infrastructure (4G-LTE or 5G) is unstable, the UAV can provide other alternatives for enabling broadband communications, e.g., WiFi or WiMAX)

#### 2.2.2.8 Post-conditions

It is expected that this use case will improve both the efficiency of the operations and the safety of the field brigades.

#### 2.2.2.9 High Level Illustration

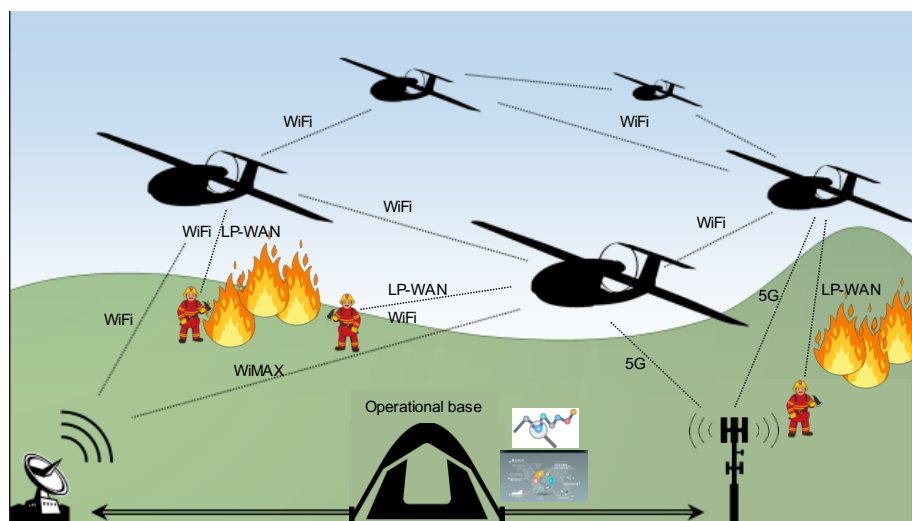

Figure 2-13: UAV as MEC nodes for emergency support operations - High level illustration

#### 2.2.2.10 Potential Requirements

The main requirements of the proposed use case are twofold:

- **Highly effective communications.** As aforementioned, depending on application scenario the U2U and U2I communications will be enabled by different communication alternatives. However, in all cases, it is demanded that these technologies provide i) stable, ii) high-bandwidth, and iii) low-latency connectivity.
- **Energy issues.** One of the main limitations of current UAVs is their batteries lifetime. For that reason, it should be considered to use low weight devices for reducing the payload on-board the UAV and also it would be highly desirable making use of low energy-consumption equipment regarding communication and processing tasks.

## 2.2.2.11 Radio Specific requirements

### 2.2.2.11.1 Radio Coverage

- Radio cell range
  - For LP-WAN based transmissions, very long transmission ranges are required (10 km LOS and 4 km NoLOS). Regarding other communication technologies such as cellular or WiMAX, transmission distances of over 1 km are required.
- Does the radio link crosses public spaces? Or is it constrained to indoor or customer premises?
  - The proposed system is devoted to work in public spaces
- Is Multicell required?
  - No, it is not required
- Is handover required? Seamless? Tolerable impact in delay and jitter?
  - No handover is required in this application
- Mobility: maximum relative speed of UE/FP peers
  - The initial proposal just considers end-terminal carried by people, but it could be extended to rescue vehicles as well.
- Special coverage needs: i.e., maritime, aerial
  - The proposed system is based on aerial communications.

### 2.2.2.11.2 Bandwidth requirements

- Peak data rate
- Average data rate
- Is traffic packet mode or circuit mode?
  - If circuit mode, is isochronicity required?
    - The system works in circuit switched mode and the bandwidth requirements differ depending on the considered transmission technology and the provided service. For example, LP-WAN technologies need very low data-rates of about 1 kbps (peak). For live video-transmissions, peak data rates of less than 10 Mbps might be enough for properly providing this service.

### 2.2.2.11.3 URLLC requirements

- Required Latency
  - (specify if it is one way or roundtrip)
- Required Reliability
  - (i.e., 99,99999%)

- Maximum tolerable jitter
  - The latency requirement for live streaming services should be lower than 10ms. Other less demanding transmissions may have more relaxed latency requirements. Similar values may be considered for the jitter.
  - Due to the adverse transmission conditions of the proposed system, it is difficult to establish a precise value for the required reliability.

#### **2.2.2.11.4 Radio regimens requirements**

- Desired and acceptable radio regimens (describe the desired and acceptable radio regimens: I.e.: licensed - public mobile, licensed – specific license, license-exempt)
  - It is envisioned the use of license-free bands.

#### **2.2.2.11.5 Other requirements**

- The UE equipment will use batteries for powering. At least, it is needed a battery lifetime of 1 day.
- The terminal location is needed with a high accuracy in order to enable efficient operation-management activities.

## **2.2.3 UAS (Unmanned Aerial System) operations in U-Space**

### **2.2.3.1 Description**

- Drones have emerged as one of the fastest growing markets for a unique ecosystem of electronics. The global commercial drone market size was estimated to be USD 552 million in 2014 and is expected to grow at a Compound Annual Growth Rate (CAGR) of 16.9% till 2022.
- Safety concerns are one of the main obstacles hindering the development of many high potential drone applications. For example, drone provided logistics are still not allowed in the US. Safety and the lack of a mature airspace management system are the primary reasons.
- As UAS are developed like IoT devices - in contrast to vehicles and aircrafts both mandated to follow many safety standards and certifications resulting in costly and weighty solutions - alternatives including redundancies possibly from other segments like IoT security and Automotive need to be defined and implemented.
- A real-time airspace management system needs a standardized communication system, so all drones can communicate with each other, their surroundings and the airspace controller.
- The main goal of Device to everything (D2X) communication is to avoid accidents. Drones are required to broadcast their UAV-ID, position, speed, heading, surrounding and other information. By establishing wireless connections between drones/infrastructure and enabling information sharing among them collision risks can be identified and avoided.

- The establishment of a communication standard for drones makes it possible to implement such a real-time airspace management system and collision avoidance system, which will further increase the possibilities and market growth for drone applications.

Example use case:

- *Preparation of drone mission:* The drone operator plans the mission with the help of U-Space services such as weather forecast, traffic density reports, flight planning assistance and anti-collision analytics services.
- *Submission of a flight request and receipt of an acknowledgement:* A flight request is submitted to the authorities which grant permission or suggest mission adjustments. While airborne the drone receives information on the local airspace conditions and broadcasts its own unique ID to allow for tracking.
- *Execution of the flight:* If the drone is equipped with a detect-and-avoid system it can safely avoid unforeseen obstacles in its flight path. Geo-fencing capability allows for flexible airspace restrictions (e.g. after accidents creating temporary non-flying zones) which prompt all drones to avoid the restricted zones based on shared information.
- *Mission completion:* After the drone arrives at its destination/completes its mission it is ready for its next mission.

#### 2.2.3.2 Source

- City ATM, Braunschweig: Demonstration of a UAV traffic management in urban airspace, see (visited in May 2018): [http://www.dlr.de/fl/en/desktopdefault.aspx/tabid-1149/1737\\_read-50670/](http://www.dlr.de/fl/en/desktopdefault.aspx/tabid-1149/1737_read-50670/)
- UAV hook on device : Testing a UAV position reporting system using 4/5G hook on devices, see (visited in May 2018): [https://www.dfs.de/dfs\\_homepage/en/Press/Press%20releases/2017/09.10.2017.-%20Drones%20saving%20lives/](https://www.dfs.de/dfs_homepage/en/Press/Press%20releases/2017/09.10.2017.-%20Drones%20saving%20lives/)

#### 2.2.3.3 Roles and Actors

- *Drone operating businesses:* The actors who conduct drone operations in U-Space.
- *Authorities / Airspace controlling entity:* National and supranational authorities who set the rules for the airspace, grant permission for drone operations and who monitor U-Space.
- *Drone manufacturers:* Build the drones for different applications corresponding to customer demand and the technical requirements of the regulated airspace (e.g. outfitted with e-identification, geo-fencing and communication capabilities).
- *Component suppliers:* For UAS as well as for the U-Space infrastructure (communication network supplier).

#### 2.2.3.4 Pre-conditions

- The drone operations rely on an existing Unmanned Traffic Management system (UTM).



### 2.2.3.5 Triggers

- Business decides to undertake a UAS operation.
- Authorities need to decide, if the conditions of the mission are sufficient for a safe UAV operation based on a risk and impact assessment.

### 2.2.3.6 Normal Flow

- The drone operator gathers all the necessary information (including geo-fencing data, meteorological data and airspace traffic data) to plan the mission and flight path.
- The mission is submitted to the relevant entities for approval. If necessary, changes to the flight path/flight time are made.
- If approved, the mission is executed accordingly. While airborne, the drone communicates with its surroundings to avoid obstacles (using detect-and-avoid) or restricted areas (via geo-fencing).

### 2.2.3.7 Alternative Flow

- Redundant and supporting communication channels should be used in case one communication fails. Currently 4G-LTE/5G and 802.11p communication are being tested.

### 2.2.3.8 Post-conditions

- The drone has completed its mission and is ready for a new assignment.

### 2.2.3.9 High Level Illustration

The blue and the green lines in Figure 2-14 represent the Device to everything (D2X) communication that could be based on 5G.

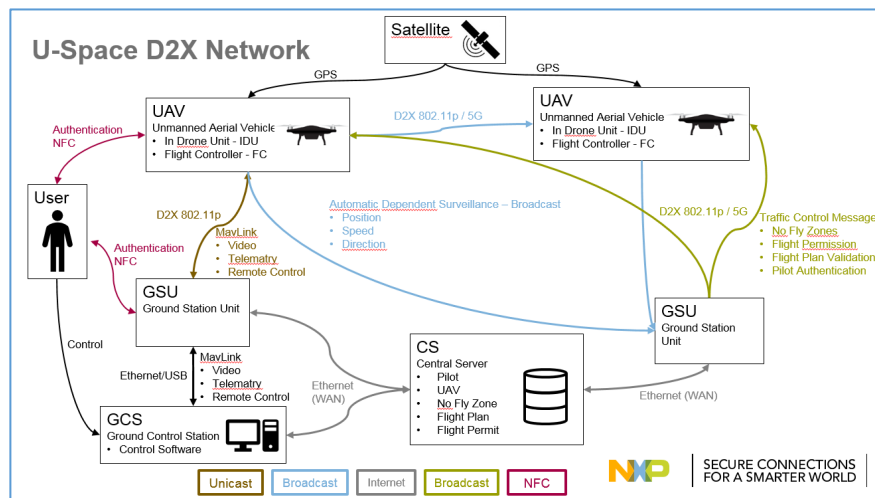

Figure 2-14: UAS operation in U-Space - High level illustration

### 2.2.3.10 Potential Requirements

UAS operations in U-Space require reliable, secure and trusted communication. UAS operations always carry a certain risk for accidents and therefore must be secure from outside interference. The system also has to be highly scalable to support many simultaneous operations in the same U-Space.

## 2.2.3.11 Radio Specific requirements

### 2.2.3.11.1 Radio Coverage

- UAS operations in U-Space would typically take place as NoLOS. UAV would therefore rely on their technical features to safely and properly execute their missions.
- Operations would take place outside in a public environment. The maximum range would only be limited by battery/fuel capacity and radio cell coverage. A ubiquitous multicell arrangement that covers wide areas of a country, including cities and the countryside, would therefore be essential to enable UAS operations. The handover between cells would need to be seamless to guarantee safe flight operations. While UAVs would be equipped with detect and avoid systems, a gap or delay in the 5G connection could lead to an increased chance of accidents.
- Additional special coverage challenges arise due to the speed and operating altitude of UAVs of up to several hundred feet.
- Typical ranges would be expected to be several kilometres. There have already been successful long-range NoLOS and Beyond Vision LOS (BVLOS) missions, including one in France where a UAV travelled 50km using a 3G network to guide the UAV.

### 2.2.3.11.2 Bandwidth requirements

For the exchange of command and control information an up- and downlink data rate of 100 kbps should suffice. Operations that include video-transmission however would necessitate much higher bandwidths of several Mbps.

### 2.2.3.11.3 URLLC requirements

Safe operations in U-Space require a roundtrip latency as low as possible and a reliability as high as possible. UAVs in U-Space rely on their 5G network connection to transmit their own positional data to others and to receive positional data from other UAVs and about geofenced areas to avoid accidents.

### 2.2.3.11.4 Radio regimens requirements

To reduce possible interferences and to guarantee a low latency a licensed spectrum for UAS operations would be desirable.

### 2.2.3.11.5 Other requirements

- Power consumption should be as low as possible. Possible UAS operations could last several hours in various environmental and weather conditions. Battery drain due to 5G usage should not be a limiting factor to UAS operations.
- UAVs use GPS to detect their location. Terminal location via 5G is therefore not required, but could be useful to facilitate failsafe redundancy provided that the accuracy is high enough.

## 2.3 Smart Energy

### 2.3.1 Future Energy Grids

#### 2.3.1.1 Description

Technological advances - accompanied in some jurisdictions by market liberalisation – along with the emergence of new energy sources often provided by prosumers at the edge of the network are transforming the energy network from a closed, monolithic and highly predictable infrastructure to an open, multi-owned, decentralized ecosystem. This poses significant challenges, both in functional (i.e. stability, resiliency and highly availability) and in non-functional (i.e. sustainability, security, privacy and Capital Expenditure / Operational Expenditure (CAPEX/OPEX)) aspects. Internet of Things and 5G technologies will deliver the technical capability to support the vision of a Smart Energy Grid. The potential prize is significant: to meet rising demand, increase the reliability and quality of power supplies, improve energy efficiency, and integrate highly distributed and low-carbon energy sources into power networks.

In particular, the last mile of smart energy grids will extensively use IoT and 5G technology: while smart energy grids observability and monitoring is already in place in the high and (mostly) in the medium voltage branches of the energy networks, the Low Voltage/Low Pressure branches are much less technologically mature. Currently, no consideration is typically given to real time energy consumption or energy production feedback from prosumers, which would allow finer-grained prediction of demand and improved load balancing of energy networks. Prosumers are considered to be homes/buildings that are able to produce and consume energy. Hence the smart energy “last mile” network represents an ideal application domain for extensive IoT and 5G deployment, where different applications with different ICT requirements have to be flexibly managed:

- *Smart Grid applications*, such as supervisory monitoring (cyber-monitoring and physical/aerial surveillance), fault localization, isolation/self-healing and energy re-routing;
- *Advanced metering applications* enabling the massive and lock-in free integration of end-user infrastructure to the grid;
- A combination of the above in areas such as smart EV charging where dispatchable demand response can be used to optimise the use of resources and minimise the possibility of power being unavailable when required.

#### 2.3.1.2 Source

[H2020 5G-PPP project NRG5](#)

#### 2.3.1.3 Roles and Actors

- Industrial and residential end users (consumers and prosumers), Energy suppliers, 5G operators, suppliers of Advanced Metering and related hardware.

**2.3.1.4 Pre-conditions**

- Extensive deployment of standards-based next generation smart meters; power infrastructure necessary to support an energy grid with multiple heterogeneous energy sources; 5G network.

**2.3.1.5 Triggers**

The supervisory monitoring (cyber-monitoring and physical/aerial surveillance), fault localization, isolation/self-healing and energy re-routing processes will be ongoing continuous processes, triggered only by the continuous requirement for actors to generate and consume energy.

**2.3.1.6 Normal Flow**

Next generation smart meters measure data at the network edge. Digital twins receive and store this data and answer queries in from applications or aggregation platforms that require the data. Analytics and simulation models are then used to generate a wide variety of key grid measurement predictions such as grid status, weather conditions, near real-time predicted future supply and production, and so on. The data is used by the applications to provide insight to energy users, suppliers and grid operators to help them optimize grid performance.

**2.3.1.7 Alternative Flow**

**2.3.1.8 Post-conditions**

The provision of an open, multi-owned, decentralized energy ecosystem, retaining crucial features from the existing more monolithic approach, both in functional (i.e. stability, resiliency and highly availability) and in non-functional (i.e. sustainability, security, privacy and CAPEX/OPEX) aspects.

**2.3.1.9 High Level Illustration**

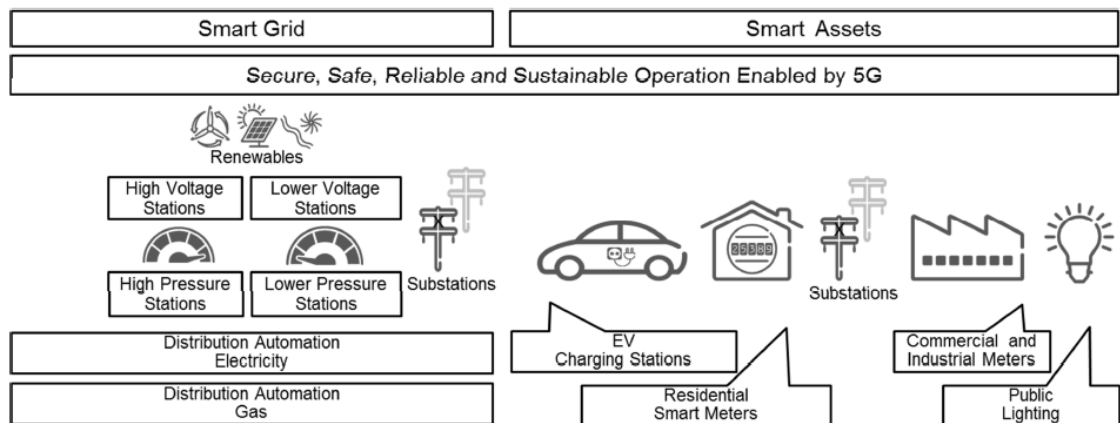

**Figure 2-15: The energy uses cases highlighting the smart assets use cases and the energy, distribution use case from smart grids, copied from [6]**

### 2.3.1.10 Potential Requirements

The frequency of data transmission, the massive number of devices involved and the low latency required make 5G an essential part of any Smart Grid solution. Thus the emergence of the Smart Grid will require availability of 3 of the principal features of 5G:

- Enhanced Mobile Broadband (eMBB),
- Ultra-reliable and Low-latency Communications (uRLLC)
- Massive Machine Type Communications (mMTC)

We exemplify the requirement for these network characteristics by reference to use cases from the NRG-5 European collaborative project<sup>1</sup>:

1. eMBB: in one use case, the project will use semi-autonomous swarms of drones to survey energy network infrastructure for the purposes of security and predictive maintenance from different views/cameras. The UAVs/Drones swarms need to run complex, bandwidth demanding, computationally heavy and time critical applications.
2. uRLLC: NRG-5 will implement the “plug & play vision” in metering resources by realizing a novel and scalable edge computing solution. Advanced Metering Infrastructure will support a ‘transactive’ energy grid in a highly decentralised and distributed environment with multiple local energy exchanges and prosumers. Accurate data reporting is key in such an environment and phasor measurement requires very low latency to ensure this accuracy.
3. mMTC: in this use case the project is managing energy network stability and resilience in the context of EVs with an open ecosystem of providers and consumers with the goal of optimising usage and minimise cost of energy, as well as ensuring energy availability. A large number of both fixed and mobile sensors will require econnectivity, thus requiring the mMTC capabilities of 5G. In addition, the uRLLC scenario elaborated in bullet (2) above, will also require mMTC with millions of devices being deployed in dense areas.

The Smart Energy performance requirements listed in Table 4 apply also to this use case.

## 2.3.2 Home Energy Display

### 2.3.2.1 Description

- Provides information on the user’s real-time power consumption, accumulated consumption, and production throughout the day/week/month/year.
- The display also gives info about the status of the power system, real-time electricity cost and environmental weight, and air quality.
- In case that the user has a PV system, would also provide the status of power generation from decentralized production.

---

<sup>1</sup> <http://www.nrg5.eu/>

- Provides predictions of power system status – cost, environmental impact, to guide user actions
- Includes advices to user of power consumption based on user’s historic behaviour, predicted power system status, and features such as peer-comparison of energy consumption or energy consumption reduction targets based on historical data.
- Technologies like NB-IoT can be used to support communication requirements imposed by this use case. However, in case of an increased decentralized energy production, higher sampling rate might be required to balance the reactive/active power, power frequency and phasing; This will impose additional communication requirements to the underlying communication technology, where the use of 5G might be required;
- Part of the Urban Agenda for the EU, established in the Pact of Amsterdam, in May 2016, include a digital transition. The Digital Transition partnership proposes initiatives on the topics where digitalization can have the most profound effect in transforming urban governance, quality and fulfilment of life of its citizens, and the most advantageous business and growth opportunities for the businesses. The partnership focuses on three vertical themes including Urban Planning. Four horizontal enabler themes are cross cutting the verticals: Data & Standardization, Business models/ Innovation accelerator, Digital skills development, and 5G / other KETs. The strong expertise in ICT has created a unique base for innovations and new business in Oulu. During 2014-16 over 500 start-ups started operating, and the amount of rented offices has over doubled within the last years. Oulu’s developing fields of technology are for example digital health, gaming, 5G and IoT.

#### 2.3.2.2 Source

- MAKING-CITY EC Horizon 2020 project (<http://makingcity.eu>)

Launched in December 2018, MAKING-CITY will address and demonstrate advanced procedures and methodologies based on **the Positive Energy District (PED)** for 60 months. A PED is defined as “a district with annual net zero energy import and net zero carbon emissions, working towards an annual local surplus production of renewable energy” in the European Strategic Energy Technology Plan (SET Plan).

#### 2.3.2.3 Roles and Actors

- Roles:
  - End-user: interaction with the display, real-time price contract
  - Power supplier: providing real-time data on power generation
  - Service provider: Feeds in data on environmental weight based on power generation method
- Actors: end-users, power companies, DSO, TSO

#### 2.3.2.4 Pre-conditions

Having a near real-time info on which power plants are operational

### 2.3.2.5 Triggers

- Data collection time periods in the order of 60 seconds; However, in the case of a highly decentralized power system and increased decentralized energy production, higher sampling rate might be required to balance the reactive/active power, power frequency and phasing, where the data collection time period will be in the order of equal or less than 20 milliseconds.

### 2.3.2.6 Normal Flow

- Data input: consumption pattern/user's action, building-integrated power generation, power system status, real-time price, environmental data
- Data output: prediction to user on the price and environmental weight of intended action, prediction of the future state when same action can be done with lower price and/or environmental impact

### 2.3.2.7 Alternative Flow

- In case user sets upper limits to total or daily power consumption, total cost or maximum GHG generation limit, can alert when approaching limits
- Could also provide carbon offset options e.g. when limits are surpassed
- Cool facts/fun facts, info?

### 2.3.2.8 Post-conditions

- On the long term to lead to improved environmental knowledge and environmentally conscious power consumption behaviour

### 2.3.2.9 High Level Illustration

<https://makingcity.vtt.fi/authtest/auth/index.html>



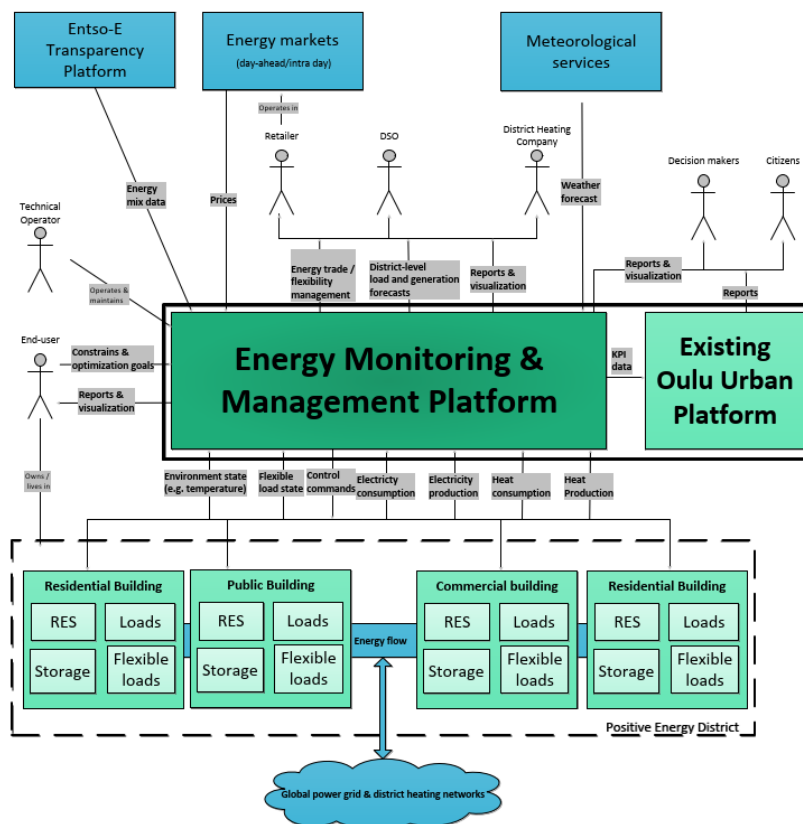
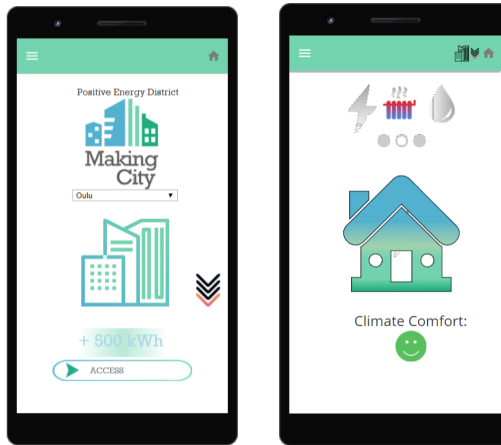

Figure 2-16: Energy monitoring and data flow of the Making-City project for automation and home display – Case of Oulu city. [45] D2.20 – Services and Modules for Oulu ICT Platform.

### 2.3.2.10 Potential Requirements

- Functional requirements:
  - Sensing networks for measuring physical properties e.g. indoor/outdoor temperature, pressure difference, ventilation flow rate, CO2 concentration, electricity consumption,
  - Data collection time period: 60 seconds  
Smart meters do not provide (near) real-time information but aggregated data packages once every day. Therefore, tiers devices are



required to read and send higher data samples to the servers and database to be used to the in-home display.

- Highly decentralized power system: In case of increased decentralized energy production, higher sampling rate might be required to balance the reactive/active power, power frequency and phasing, where the data collection time period is in the order of equal or less than 20 milliseconds
- NB-IoT technologies may be required to access individual appliances or other devices inside homes.
- Tablet
- Online web application
- in-home sensors and smart plugs
- connectivity with service provider's data
- weather data
- data from DSO and TSO
- Non-functional requirements – possible consideration includes:
  - Flexibility  
The system design need to integrate flexibility in number of sensors and sampling frequency in order to
  - Scalability
    - if e.g., panels are co-owned, how to share among owners?
  - Interoperability: Important topic that is being addressed in the MAKING-CITY project
  - Reliability
    - price data is currently mainly prediction based on historic data
    - Smart metering are more precise but deviation in measurements should be addressed in accordance with the metering standards and measurements deviation [46], [47] in time using the EU standards: IEC-62052, IEC-62053, EN 50470
  - Safety: Being energy domain, a high level of trust is needed
  - Security and privacy
    - Power consumption is personal, therefore GDPR applies; Moreover, since this use case is related to energy domain the Security of the underlying data infrastructure need to follow security by design principles
  - Trust:
    - High level of trust is needed

#### 2.3.2.11 Radio Specific requirements

To be studied in the EC Horizon 2020 MAKING-CITY project.

## 2.4 Smart Agriculture

### 2.4.1 Smart Irrigation

#### 2.4.1.1 Description

The motivation of the use case is the increasing demand and market for smart agriculture that is expected to grow from USD 13.7 billion in 2015 to 26.8 billion by 2020.

Farmers demand IoT-based advanced technologies and solutions to improve operational efficiency, maximize yield, and minimize wastage through real-time field data collection, data analysis, and deployment of control mechanism.

The aim of smart agriculture solutions is to increase productivity, food security, and efficiency of agricultural processes. There are different applications of smart agriculture:

- Precise farming entails the obtaining of real-time data on the conditions of crops, soil, and air.
- Smart irrigation measures various parameters such as humidity, soil moisture, temperature, and light intensity to calculate the precise requirements for water. It has been proved that such mechanism can contribute to higher irrigation efficiency.
- Smart greenhouse allows farmers to cultivate crops with minimal human intervention. Climatic conditions such as temperature, humidity, luminosity, and soil moisture are continuously monitored inside a greenhouse. Variations in these conditions will trigger automated actions. These actions will then evaluate the changes and implement corrective actions to maintain optimal conditions for plant growth.
- Precision Livestock Farming supports real-time monitoring of productions, health, and welfare of livestock to ensuring optimal yield.

In particular, this use case is based on the solution “IrrigNET -Plant-specific model-based irrigation using Internet of Things (IoT)” that is developed in [FRACTALS \(Future Internet Enabled Agricultural Applications, FP7 project No. 632874\)](#). The mathematical models of a specific crop (initially sugar beet) and soil structure are fed with data generated by sensors deployed in the field (soil temperature, humidity), current weather conditions and weather forecast to create an “irrigation recipe”, i.e. how much water should be used at a given time.

#### 2.4.1.2 Source

The initial version of the irrigNET solution is developed with the support of [FRACTALS \(Future Internet Enabled Agricultural Applications, FP7 project No. 632874\)](#), under the funding framework of the European Commission. FRACTALS supports innovative ICT SMEs and web-entrepreneurs to develop IoT-based applications with high market potential, addressing the needs of the agricultural sector.

### 2.4.1.3 Roles and Actors

Below, the main actors and their roles are identified in the use case of smart irrigation using cellular IoT technologies:

- ICT hardware and software suppliers: Suppliers of ICT hardware and software solutions required in Smart Irrigation scenarios.
- Smart Irrigation application developer: Supplier of novel and advanced Smart irrigation applications.
- IoT platform providers: used to deploy and provide the IrrigNET service in the cloud.
- Telecommunication operators: communication network operators that provide access for cellular IoT devices in different deployments.
- End-users are owners of greenhouses or crops in agriculture sector.

### 2.4.1.4 Pre-conditions

To enable the use case, the pre-condition is 5G connectivity in the crops and farms where IoT devices must be deployed for monitoring the ground and weather conditions and for control the irrigation process.

### 2.4.1.5 Triggers

For this use case, the trigger is the farmers' demand of solutions to reduce their costs of water and energy consumptions in order to be more competitive.

### 2.4.1.6 Normal Flow

Each device sends periodically sensor data and waits the answer of the IoT platform. If the platform has new configuration, the platform includes this configuration in the answer message to send toward the device.

### 2.4.1.7 Alternative Flow

No alternative flows are identified.

### 2.4.1.8 Post-conditions

The IrrigNET solution defines the exact time of irrigation as well as the exact amount of water to be used, based on the field measurements, soil type and specific needs of the plant, taking into account forecasted temperature and rainfall as well.

The IrrigNET solution provides:

- Efficient irrigation using IoT technologies
- Yields and crop quality improvement
- Rational water consumption
- Reduction of harmful effects on land

IrrigNET is available for many different crops: corn, soybean, sugar beet, potato, onion, cucumber, paprika, vineyards, and blueberries. New crops are being added continuously and can be made on request.

### 2.4.1.9 High Level Illustration

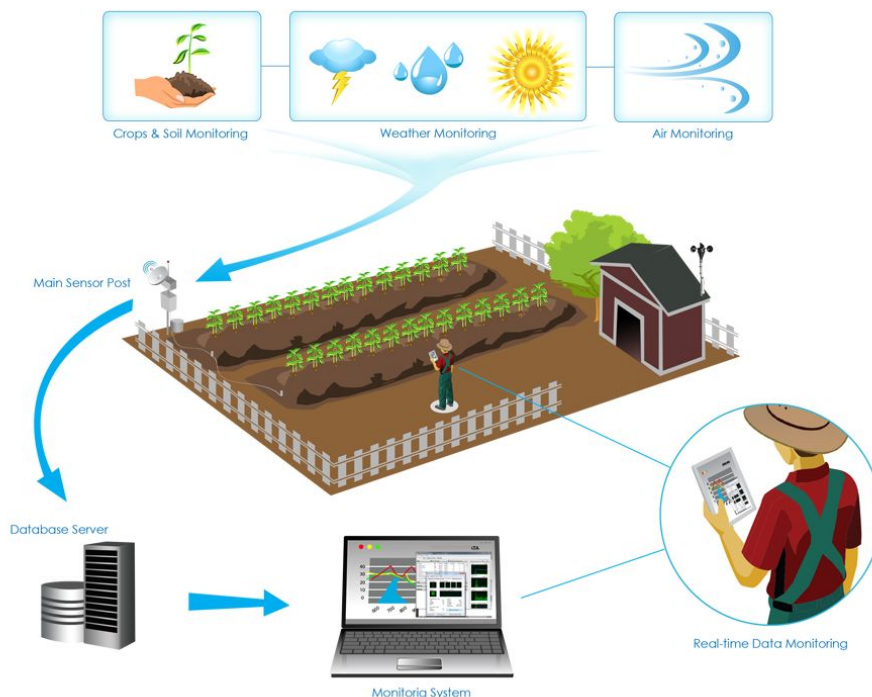

Figure 2-17: Smart irrigation - High level illustration

### 2.4.1.10 Potential Requirements

Smart irrigation requires NB-IoT devices with high network coverage, high battery life and low device cost to be deployed in farms and crops where there are not power supply and traditional mobile connectivity. The reliability and security are two main requirements that must be provided by the IoT solutions of smart irrigation based on wireless devices and cloud platforms.

### 2.4.1.11 Radio Specific requirements

Requirement		Explicit 5G Promises	Smart Irrigation
Real-time Latency	capability-	5 ms (e2e)	5 ms (e2e)
Real-time Jitter	capability-	-	-
Bandwidth		Peak data 10Gbps	10 Kbps .. 100 Kbps
Time period of information loss during failures		-	none (seamless failover)
Availability / coverage		-	ubiquitous

<b>Range (distance between communication neighbours)</b>	-	< 10 Km
<b>Reliability</b>	99.999%	99.99%
<b>Mobility</b>	500 Km/h	none
<b>Outdoor terminal location accuracy</b>	< 1 m	none
<b>Multi-tenant support</b>	yes	yes
<b>Non-standard operating conditions</b>	energy reduction by 10	Battery powered device with >1 year lifetime
<b>Harsh environment (weather)</b>		
<b>Ease of use</b>	-	Plug and Play device (sensor and actuators)
<b>Communication service approach</b>		
<b>SLA Tooling</b>	-	Service Level Agreement (SLA) monitoring
<b>Service deployment time</b>	90 min	days
<b>Private 5G infrastructure</b>	-	no
<b>Scalability: Number of devices per km2</b>	1.000.000	1000
<b>Globally harmonized definition of Service Qualities</b>	-	-
<b>Technology availability</b>	-	> 25 years
<b>Globally simplified certification of ICT components</b>	-	Yes
<b>Assured Guarantees</b>	-	mandatory

#### **2.4.1.11.1 Radio Coverage**

- Radio cell range
  - Long range (> 10 Km) under LOS and NoLOS conditions.
- Does the radio link crosses public spaces? Or is it constrained to indoor or customer premises?
  - The radio link crosses public spaces mainly outdoors, given the monitoring features for smart irrigation.
- Is Multicell required?
  - Multicell is not required.
- Is handover required? Seamless? Tolerable impact in delay and jitter?
  - Handover is not required.
- Mobility: maximum relative speed of UE/FP peers
  - Mobility is not required.
- Special coverage needs: i.e., maritime, aerial
  - No, only terrestrial.

#### **2.4.1.11.2 Bandwidth requirements**

- Peak data rate
  - 100 Kbps.
- Average data rate
  - 10 Kbps.
- Is traffic packet mode or circuit mode?
  - Packet mode

#### **2.4.1.11.3 URLLC requirements**

- Required Latency
  - Usually roundtrip communication with latency tolerance up to 1 second.
- Required Reliability
  - 99,99% (no tolerant to losses)

#### **2.4.1.11.4 Radio regimens requirements**

- Desired and acceptable radio regimens
  - When possible, it is preferred license – public mobile, in order to improve interoperability support and wide coverage of the service.

#### **2.4.1.11.5 Other requirements**

- UE power consumption
  - Rechargeable or primary battery?
    - When solar panels can be deployed, a rechargeable battery should be used for the IoT device.
  - Acceptable battery life
    - At least enough to cover a crop lifetime (e.g. one year).
- Is terminal location required? Location accuracy?
  - No, the location is usually not required.

## 2.4.2 Precision Livestock Farming

### 2.4.2.1 Description

Precision Livestock Farming (PLF) is the application of Information and Communication Technologies (ICT) in real-time monitoring of livestock and efficiency of related processes [8]. In this context, technology (e.g. cameras, microphones and  $\rightarrow\rightarrow$  sensors) can be used in order to perform automatically continuously monitor, to help farming manage their animals. PLF applies control engineering with the aim of optimizing production and management processes. Several publications in that context have been written. Here we focus mainly in the data-centric livestock farm management, i.e. an approach focused on data to support data intensive business processes, in a smart environment (Figure 2). The goal of PLF is to have a general idea of the state of the animals and their environment considering the main parameters of animal health, behaviour and growing performance. Thus, PLF can contribute to the improvement of animal health, by monitoring and analysing relevant farm or market parameters associated to the processes that have impact in efficiency and profitability of the farm management tasks. Benchmarking allows the comparison of various companies' business processes and performance metrics, giving the possibility to the systems to learn and support in high level decisions. Data-centric livestock farm management relates to all these features providing solutions to monitor, collect and evaluate data from implemented processes.

The manager using such solution can control the livestock farming, accepting or not the data analysis results by comparing its own results with those of other companies. Several stakeholders can benefit from a chain of enterprises that could work having some open data as: livestock farming companies, IoT Devices manufacturer, Communication Network supplier/provider/operator and IoT platform provider.

In Figure 2-18 it is illustrated how in a PLF use case, after equipping the smart farm with electronic sensors (step 1), the manager will be able to monitor farm processes (step 2), through benchmarking his data with other livestock companies (step 3).



Figure 2-18: Data-centric livestock farm management

### 2.4.2.2 Source

None



#### 2.4.2.3 Roles and Actors (more details are provided in Annex 1)

- Farmers / managers – profits from the Data-centric livestock farm management service increasing the probability by taking appropriate decisions based on data monitoring and benchmarking.
- IoT platform provider – operates an IoT platform collecting data from animals, and the environment. The required information is given to the services that subscribe the IoT platform.
- Data-centric livestock farm manager provider – party that provides Data-centric livestock farm manager service.
- Communication network supplier / provider / operator –Supplies and/or provides and facility connectivity.
- IoT devices manufacturer – that senses the environment and animals. Is the responsibility of IoT devices to send data to the IoT platform? Additionally, can receive data from the platform.

#### 2.4.2.4 Pre-conditions

The farm is equipped with electronic sensors supported by a 5G communications provider.

#### 2.4.2.5 Triggers

- The PLF monitoring function is activated

#### 2.4.2.6 Normal Flow

1. Farm or market variables corresponding to the processes that will have impact on farm profitability are measured electronically. Appropriate monitor parameters are:
  - animal parameters (e.g. daily weight gain, feed conversion ratio, feed consumption, body composition, body conformation, stress levels, antisocial/ normal behaviours, oestrus detection)
  - environmental parameters (e.g. ambient climatic conditions, humidity and internal air and floor temperature, air speed, floor and animal wetness, gas levels, dust levels, airborne pathogen levels).
2. The IoT platform hosts the collected data from the sources of each livestock farm. Upon request the IoT platform will send it to the farm monitoring/benchmarking application.
3. Processed information from environment/animals is send back to IoT platform and is made available to all monitoring/benchmarking subscribed livestock farms companies.
4. Each manager is responsible for interpretation and action based on the received monitoring/benchmarking application data.

#### 2.4.2.7 Alternative Flow

- None

#### 2.4.2.8 Post-conditions

- Farm stays in monitoring mode until monitoring function is being deactivated.

### 2.4.2.9 High Level Illustration

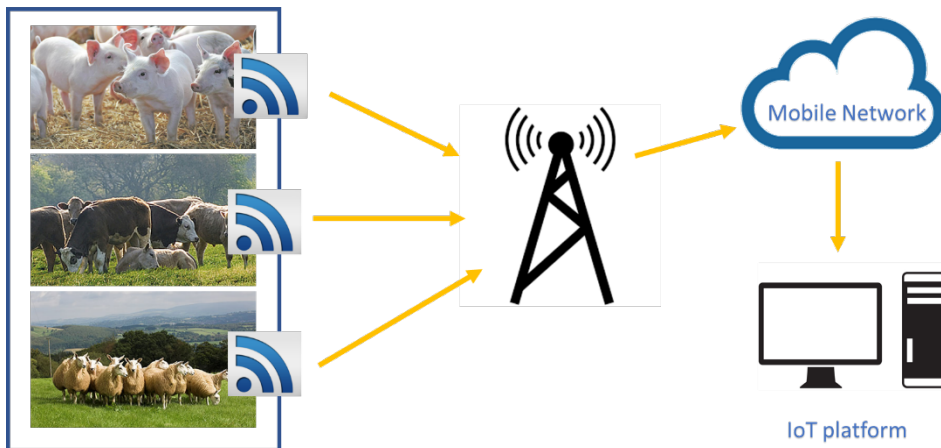

Figure 2-19: Example of IoT data streams and corresponding communication networks

### 2.4.2.10 Potential Requirements

The data-centric livestock farm management is a System-of-Systems (SoS). Its functionality can be divided into two key components. One component is focused on the creation of a smart farm environments, and the other on data analytics related to management activity, i.e., farms monitoring and benchmarking.

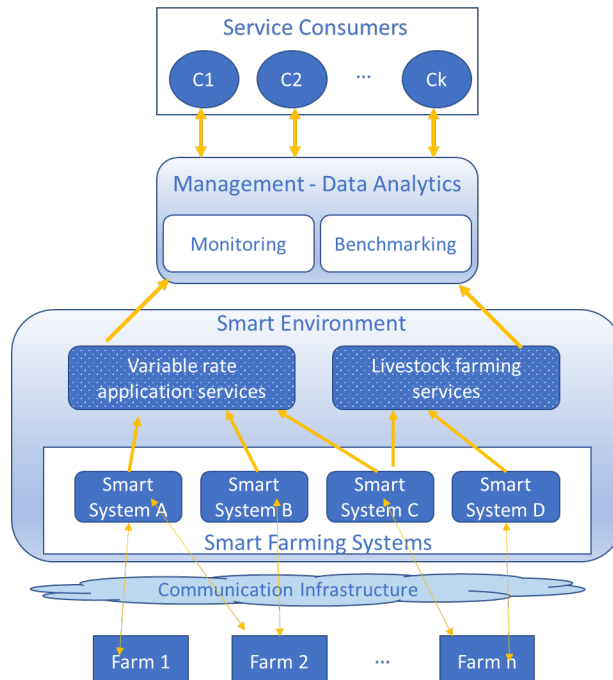

Figure 2-20: Example of a System-of-systems to an IoT based a data-centric livestock farm management

The system must be able to acquire data despite data volume, velocity and heterogeneity. Probably it will be not needed to maintain all input data. Data of different structures can be organized in a common schema to facilitate further knowledge creation and formalization. The system must be fast and efficient, in order to support the processing requirements.

Concerning real-time analytics, the system performance must be reasonable regarding the user's speed of thought meaning able to predict some situations requiring high speed events processing allowing timely reactions to problems and opportunities. Interactive dashboards must provide display of information and analysis useful for the user. Data mining, machine learning, and statistical analysis allow the user to understand past occurrences and support future decisions.

Regarding intelligent processes, the system must allow the user to make more informed decisions. Additionally, the system might provide insight and support performance and management processes of business.

The implementation requires a cloud platform accessible via 5G technology to which data can be transferred and accessed from a different set of platforms. It is expected that 5G will be able to support the requirements imposed by data-centric livestock farm management use case. Next are described three different aspects concerning radio specific requirements for this use case?

#### **2.4.2.11 Radio Specific Requirements**

The main or general radio requirements are related to 5G pre-determined characteristics that may contribute to support the described data-centric farm management and to implement smart farm environments. However in this case three main aspects may be considered when defining such radio specifications that are:

- 1. live video streaming;**
- 2. Sensor and tracking devices with low energy consumption; and**
- 3. Event processing & data handling precision**

##### **Live video streaming**

Thus, in relation to live video streaming, which relates to support the analysis of health conditions of the animals with real time videos the radio requirements ends up more in general specification of 5g that are described in the following.

According to Badic et al. [9] 5G is focusing on 3 main pillars:

- More spectrum – access to a new spectrum in the upper mmWave bands and new spectrum usage paradigms such as spectrum sharing
- More spectrum efficiency – not necessarily in term of link capacity as described in Shannon's Theorem, but through better exploitation of the entire heterogeneous environment
- Denser deployment - to be enabled using small cells

According to the same authors, it should:

- support billions of devices and users connected around the world and support diversity of services and applications.

- deliver 1000 to 10000 times higher cell capacities and user data rates than previous versions
- deliver low latencies to avoid the bottleneck of radio interface and to ensure real-time reliable connections
- offer both high coverage and availability. Additionally, difficult and specific geographic areas should be covered by this network.
- be scalable and flexible to deliver high energy efficiency.
- Maximum output power levels and aggregate power budgets need to be achieved
- Typical 4G devices form factors, i.e. its overall design and functionality, need to be supported for mass market 5G. Additionally, specific tailored form factors and software adaptations will be required.
- In a recent future, 2G, 3G, and 4G systems should be maintained available.
- 5G systems will accede to additional frequency bands.

Such 5G pre-determined characteristics as described in [8], are:

- Reliability: 99.999%
- Service Deployment time: 90 minutes
- Energy efficiency: 10% of the current consumption
- Number of devices: 1 M/km<sup>2</sup>
- Mobility: 500km/h
- Peak Data Rate: 10 Gb/s
- Mobile Data Volume: 10 Tb/s/km<sup>2</sup>
- E2E Latency: 5 ms, this may be a much lower number (1ms)

### **Sensor and tracking devices with low energy consumption**

In the IoT paradigm everything and everyone can be connected. That reshapes the way individuals interact both with each other and things. The number of worldwide connected devices is increasing.

Concerning position, Silva et al. [10] emphasized the following relevant IoT system parameters:

- Topology
- Range
- Channel bandwidth
- Modulation type
- Positioning signalling or data exchange
- Roaming
- Network ownership
- Power Consumption

The same study summarily analysed the key position aspects for several protocols and reported the key physical layer parameters for several IoT protocols. In that context, NB-IoT, which belong to the class of “Non-global navigation satellite system positioning” technology, is characterized by:

- Network topology: star
  - Network Type: LR / LP-Long range
  - Time-Based Positioning: low
  - Space-Based Positioning: medium
  - Achievable Positioning Accuracy: Medium
  - Most Suitable Domain: Time
- In order to fulfil technical requirements to implement 5G, i.e., improve spectral efficiency; high traffic density; massive connectivity; lean design; support for cmWave and mmWave transmissions; and mainly in relation to the integration of LTE and 5G Radio Access Technology (RAT) several key components can be used as can be seen in Figure 2-21.

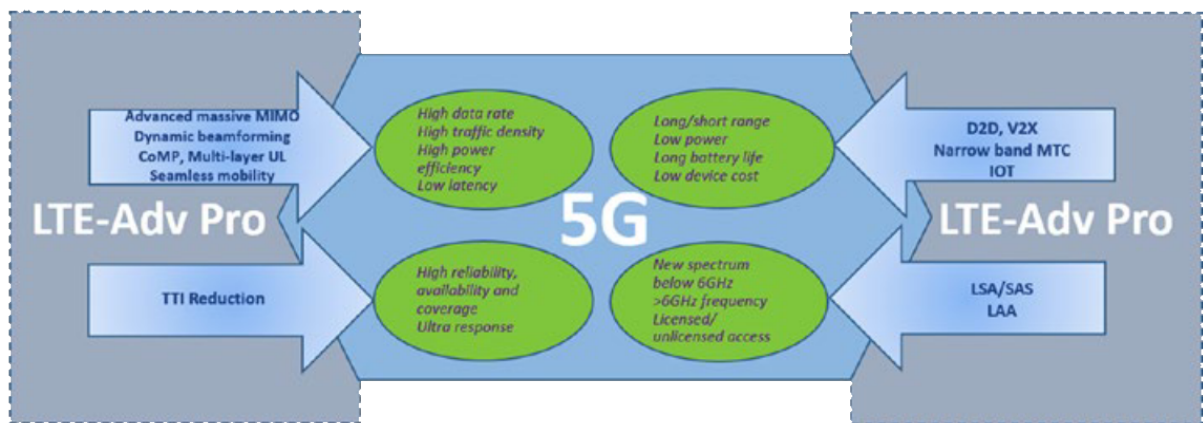

Figure 2-21: LTE-Advanced Pro features and 5G requirements [9]

One of those technologies is Narrowband Internet of Things (NB-IoT), which is built from LTE functionalities, and designed to achieve the following targets to support the use of sensor and tracking devices mainly in relation to:

- Low-cost design devices
- High coverage (20dB improved over GPRS)
- Long device battery life (more than 10 years)
- Massive capacity (52K devices per channel per cell)

Additional NB-IoT specifications are next described (Table 1):

Specifications	NB-IoT
Extended coverage and distance	20dB better compared to <u>GSM/GPRS</u> , covers less than 22 km from cell
Frequency spectrum	700 MHz, 800 MHz, 900 MHz
Bandwidth	180 kHz to 200 kHz
Capacity-Number of Connections	50 K connections per cell, supports about 40 devices for <u>household</u>

Power Consumption	Very low power consumption and hence extends battery life to 10 years
Latency	Less than 1 seconds ( <u>uplink</u> )
Data rate	200 kbps
Transmit Power	+20 dBm or +23 dBm
Drive Cost	Low, which is under \$5 per module

Table 1: narrowband (NB-IoT) specifications.

Concerning the frequency spectrum, NB-IoT has three operation modes:

- Standalone deployment utilizes new bandwidth
- Guard band deployment type uses bandwidth reserved in the guard band of existing LTE network
- In-Band deployment type uses same RBs (resource blocks) in LTE of existing LTE network bands

### Data Handling Precision

This topic mainly relates to a previous term introduced in the domain that is “precision farming”. According to the Home Grown Cereals Authority it relates to the “management of farm practices that uses computer, satellite positioning systems and remote sensing devices to provide information on which enhanced decisions can be made”. The plausible technology to allow the realization of new technological applications in the scope of “precision farming” branch is 5G. In this case the “precision” relates to the capability of real time events processing that requires an effective handling of speed and accuracy in relation to those events. Thus in the following it is introduced the work that has been happened in relation to the introduction to specific standards to handle such accuracy handling such high speed communications in the support of such events processing.

5G is to provide lower latency compared with 4G, a possible solution to accomplish that can be by distributing intelligence across the network and insert intelligence in the radios. Another possibility is to increase the speed of both transport and switching [9]. International Telecommunication Union defends that “with the emerging 5G standard, available bandwidth is increasing, latency is going down, and new services are being introduced that are driving tighter synchronization requirements” [12].

According to the same source, new protocols such as Precision Time Protocol (PTP), as well as other standards have been developed to support time and frequency synchronization. PTP has been specified in the IEEE 1588-2002 standard. However, its actual version is called

PTPv2, introduced in IEEE 1588-2008. It specifies the protocol for time and frequency synchronization in packet networks, providing a flexible framework.

As the systems become more complex involving sensors, actuators, and computers distributed in the space and communicating via networks the specific conceptualization of time is required to implement robust systems. The "Precision Livestock Farming" system can be seen as a target application for IEEE-1588 since it can be considered time-based, i.e., "the execution of events is based on common sense of time" [13] in which, according to Eidson et al. [14], "synchronization accuracy depends on the accuracy of the common sense of time and the implementation of the participating devices, rather on precise control of messaging latency". Considering the same authors, the common sense of time could be implemented using a local clock in each participating node synchronized to its peers via a protocol such as IEEE-1588. Additionally, the synchronization accuracy of those clocks depends on the application. Furthermore, IEEE-1588 is designed to cover specifications of networking, heterogeneous systems, cost, special scale, low administrative overhead, typical requirements of target application areas of IEEE-1588, in which is included the "Precision Livestock Farming" system. Requirements of the last version of IEEE-2008 includes: high accuracy, varied update rates, linear topology, and rapid reconfiguration after network changes, fault tolerance.

The goals of IEEE 1588 are the following [14]:

- The protocol must to enable real-time clocks in the components of a distributed network measurement and control systems to be synchronized to sub-microsecond accuracy. A real-time clock in this context is a clock within a time scale approximately commensurate with the international second
- The protocol must operate over local area networks that support multicast communications." Ethernet is the obvious candidate.
- The protocol is designed to operate on a relatively localized network system typically found in test and measurement or industrial automation environments at the bench or work cell level. Such environments are usually contained within tens or, at most, a few hundred meters spatially, and with few network components, such as switches or routers, present. The protocol was not designed to operate over the internet or wide area network
- The protocol must accommodate clocks with a variety of accuracy, resolution, and stability specifications.
- The protocol is designed to be administration-free, at least in the default mode of operation
- The protocol is designed within minimal resource requirements both in terms of network bandwidth, and computational memory capability in devices.

## 2.5 Smart Manufacturing

### 2.5.1 Communication in car manufacturing

(Communication capacity in a flexible, modular production area)

#### 2.5.1.1 Description

- The characteristic parameters were inferred from production areas in car manufacturing. The particular lifecycle phase addressed is engineering and commissioning of a flexible, modular production area

#### 2.5.1.2 Source

- 3GPP SA1 TR 22.804 (Study on Communication for automation in vertical domains), see [15].

#### 2.5.1.3 Pre-conditions



The areas in the production hall are divided into operation areas (e.g., assembly stations) and logistic areas. Some of these areas may overlap. The horizontal hall dimension of a car production, for instance, is typically 400 m x 250 m and less. The hall is typically divided in a process area and a two times smaller logistic area. This description is generic and independent of the communication technology used.

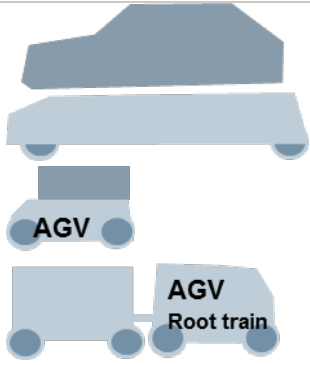
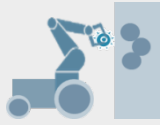

#### 2.5.1.4 Condition with Potential Requirements

Type of assembly device and activity	Characteristic parameters	Maximum # of active devices per 10 m x 10 m	Maximum # active devices in a LOS space (note 1)
Monorail, e.g., flexible rail-mounted shuttle system for logistic support 	Jitter: < 50% of cycle time During movement: - cycle time 10 ms to 100 ms; - message size 25 Kbyte.	2	50
Logistic devices, e.g., AGVs, root trains, mobile robots	Jitter: see Subclause 5.3.7.6. During movement: - cycle time 40 ms to 500 ms; - message size 25 Kbyte.	4	450

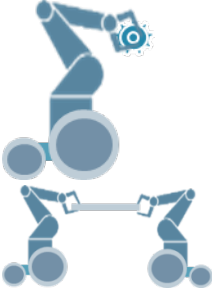

	<p>Operation, i.e., during a stop at an assembly area: event-driven non-deterministic communication (messages related to order management, asset communication, status information exchange, etc.)</p> <p>User-experienced data rate 15 kbit/s (note 2).</p>		
<p>Logistic devices: mobile robots for logistic support (autonomous navigation)</p> 	<p>Jitter: see Subclause 5.3.7.6.</p> <p>During movement:</p> <ul style="list-style-type: none"> <li>- cycle time 40 ms to 500 ms;</li> <li>- message size 25 Kbyte.</li> </ul> <p>Operation, i.e., assembly on location: interactions with other assets (e.g., loading or off-loading goods).</p> <p>- Periodic traffic:</p> <ul style="list-style-type: none"> <li>- cycle time 1 ms to 50 ms;</li> <li>- message size &lt; 25 Kbyte.</li> <li>- The user-experienced data rate for a-periodic traffic (event-driven non-deterministic messages, e.g., information for order management, asset communication, status info</li> </ul>	4	100

		exchange, etc.) is 15 kbit/s (note 2)		
<p>Process devices: mobile robots for assembly (autonomous navigation)</p> 		<p>Jitter: see Subclause 5.3.7.6.</p> <p>During movement:</p> <ul style="list-style-type: none"> <li>- cycle time 40 ms to 500 ms;</li> <li>- message size 25 Kbyte.</li> </ul> <p>Operation, i.e., assembly on location (cooperative interactions with fixed and mobile assets):</p> <ul style="list-style-type: none"> <li>- cycle time 1 ms to 10 ms;</li> <li>- message size &lt; 25 Kbyte.</li> </ul>	4	80
<p>Process devices: tool localisation and communication</p> 	tool and	<p>During assembly:</p> <ul style="list-style-type: none"> <li>- localisation of tool;</li> <li>- time to first fix &lt; 1 s;</li> <li>- update time of position: 100 ms;</li> <li>- position accuracy better than 1 m.</li> <li>- Communication of status and quality data (e.g., torque curve + other information needed for screw coupling): user-experienced data rate up to 30 Kbit/s. Inactive periods:</li> <li>- cycle time: 60 s;</li> <li>- message size: 200 byte.</li> </ul>	4	500

<p>Process augmented assistance (VR, Screens) and video support</p> <p>devices: video (VR, tablets, and video)</p> 	<p>Jitter: for augmented video assistance see Subclause 5.3.10.6 and for video support Subclause 5.3.9.6.</p> <p>Augmented VR</p> <p>Cooperative interactions with fixed and mobile assets:</p> <ul style="list-style-type: none"> <li>- cycle time 17 ms;</li> <li>- picture size (compressed): <ul style="list-style-type: none"> <li>- 840 Kbit upstream (3x8 b; width 1080 pixels; 60fps);</li> <li>- 370 Kbit upstream (3x8 b; width 720pixels; 60fps).</li> </ul> </li> </ul> <p>Video augmented overlay:</p> <p>DL end-to-end latency &lt; 10 ms</p> <p>Video support:</p> <p>12 Mbit/s to 50 Mbit/s (1080p, H.265).</p>	5	350 (note 3)
<p>IT communication: firmware download to the MPSC and of, e.g., log files to field devices (PLCs, embedded controller)</p> 	<p>Non-deterministic aperiodic communication; peak aggregated user-experienced data rates for file transfers: at least 10 Gbit/s within an area of 500 m2.</p>	3	20
VoIP	VoIP streams according to G.711 over the whole area.	5	300

			
---	--	--	--

NOTE 1: Active devices in a line-of-sight (LOS) space, i.e., # of devices in a space with obstructions but without walls that block the propagation. Devices that are not synchronised with each other can give rise to user-plane data bursts in the 5G system.

NOTE 2: The response time needs to be 100 ms. The implication for the end-to-end latency has to be inferred for individual deployments.

NOTE 3: 15% of all devices use event-driven video support.

## 2.5.2 High performance manufacturing

### 2.5.2.1 Description

Use cases in manufacturing apply sequence-control mechanisms with highly deterministic and periodic (or cyclic) message exchanges that have stringent requirements on latency, reliability and isochronism. Some of these use cases fall under the following categories:

- Motion control,
- Control-to-control communications,
- Mobile robots,
- Massive wireless sensor networks.

These use cases rely on industrial Ethernet for communications among the various nodes such as sensors, actuators, controllers, bridges and gateways. The Ethernet network might support different, use-case- or deployment-specific topologies such as ring, star, tree or mesh.

The Time-Sensitive Networking (TSN) framework establishes a set of specifications to meet the strict performance requirements of high performance manufacturing. For the present use cases, the following TSN features are relevant:

- Clock synchronization among all Ethernet nodes (IEEE 802.1AS, which leverages Precision-Time-Protocol PTP defined by IEEE 1588)
- Time-aware scheduling for hard real-time (RT) traffic (IEEE 802.1Qbv, integrated into IEEE 802.1Q-2014)
- Frame pre-emption to manage coexistence of less performance-constraint traffic with hard-RT traffic (IEEE 802.1Qbu, integrated into IEEE 802.1Q-2014).

### 2.5.2.2 Source

- 3GPP SA1 TR 22 821 (Feasibility Study on LAN Support in 5G), see [16].

### 2.5.2.3 Pre-conditions

An Ethernet network in a high-performance manufacturing location has mesh topology, where one or various links use 5G. The Ethernet network enforces TSN features defined by IEEE 802.1AS, IEEE 802.1Qbv and IEEE 802.1Qbu to support a set of coexisting hard-RT and lower-priority traffic classes. One Ethernet node runs a grand master (GM) for clock synchronization. Various links are configured to perform time-aware scheduling for a set of the hard-RT traffic classes. The Ethernet nodes interconnected by 5G PDU sessions have means to appropriately conduct clock synchronization across the 5G link.

### 2.5.2.4 Normal Flow

Periodically, synchronization messages are propagated by the GM throughout the Ethernet network. These messages may traverse the 5G links in either direction. The 5G technology

ensures sufficiently accurate determination and propagation of link delay and residence delay.

Based on clock synchronization and time-aware schedules, hard-RT traffic propagates across the network without colliding with lower priority traffic. At the same time, lower priority traffic propagates in resource-efficient manner.

On the 5G links, forwarding of hard-RT traffic is conducted in compliance with the time bounds configured via time-aware scheduling. Further, lower-priority traffic is forwarded in resource-efficient manner across the 5G links, without impacting the stringent performance targets of hard-RT traffic. Hard-RT and lower-priority traffic may flow in both directions across the 5G links.

#### **2.5.2.5 Post-conditions**

The performance targets for hard-RT traffic are met. All hard-RT traffic frames can be delivered with expected reliability within the absolute time bounds configured. Further, remaining resources are efficiently used for transport of lower priority traffic.

#### **2.5.2.6 Potential Requirements**

For infrastructure dedicated to high performance Ethernet applications, 5G system shall support clock synchronization defined by IEEE 802.1AS across 5G-based Ethernet links with PDU-session type Ethernet.

For infrastructure dedicated to high performance Ethernet applications, the 5G system shall support clock synchronization defined by IEEE 802.1AS across 5G-based Ethernet links and other Ethernet transports such as wired and optical (EPON).

For infrastructure dedicated to high performance Ethernet applications, the accuracy of clock synchronization should be below 1 $\mu$ s.

For infrastructure dedicated to high performance Ethernet applications, the 5G system shall support time-aware scheduling with absolute cyclic time boundaries defined by IEEE 802.1Qbv for 5G-based Ethernet links with PDU sessions type Ethernet.

For infrastructure dedicated to high performance Ethernet applications, absolute cyclic time boundaries shall be configurable for flows in DL direction and UL direction.

Annex 1: Supporting material of IEEE Clock Synchronisation and Time-aware Scheduling  
Network-wide Clock Synchronization

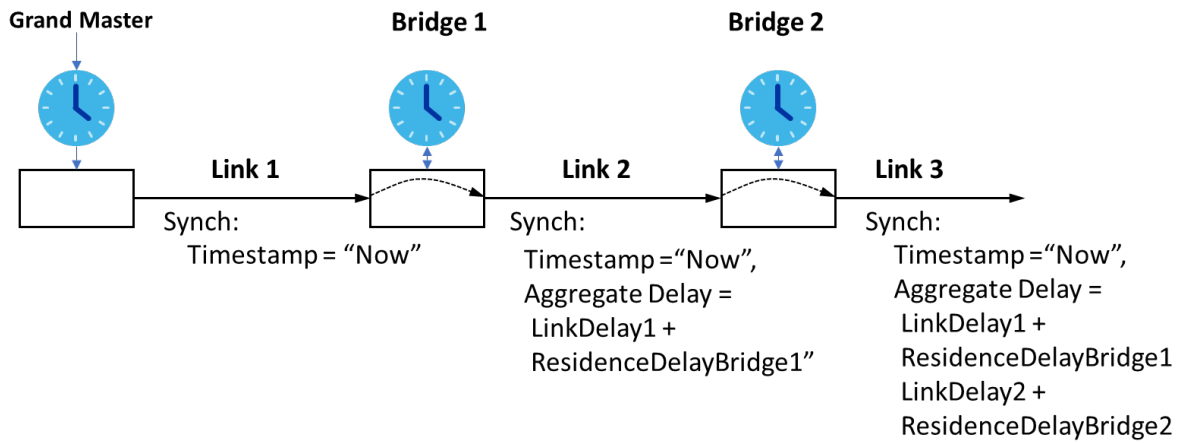

Figure 2-22: IEEE 802.1AS clock synchronization

IEEE 802.1AS achieves network-wide clock synchronization by propagating a synchronization message with a timestamp generated by a grand master (GM) hop-by-hop across the network (Figure 2-22). Bridges receive time information on one port and propagate it on all other ports. In addition, the aggregate delay of the Synch message since departure from the GM is updated at each hop and forwarded, too. The update includes link delay, which is due to propagation across the link, as well as residence delay, which is due to processing inside the bridge. IEEE 802.1AS determines link-delay via an RTT-measurement on Ethernet layer, which leverages precise timing information from the underlying physical layer.

The IEEE 802.1AS specification assumes that the link delay is symmetric and deterministic. In case it is not symmetric, adjustments have to be taken on lower layers to make it appear symmetric to IEEE 802.1AS.

Since the GM can reside on any node in the Ethernet topology, propagation of IEEE 802.1AS messages and delay measurements may have to be supported in both directions of the Ethernet link.

### Time-aware Scheduling

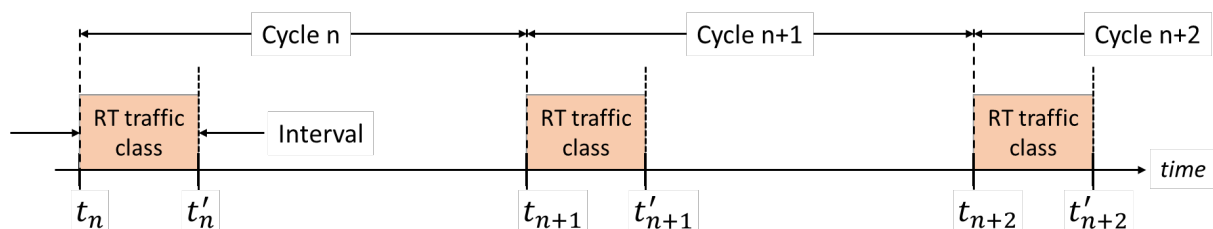

Figure 2-23: Example for time-aware scheduling with absolute time bounds

Time-aware scheduling defined by IEEE 802.1Qbv introduces absolute, periodic time bounds to the data delivery for hard-RT applications (Figure 2-23). The traffic bounds are referenced to the transmitting node's clock, which is also used by the hard-RT application. In this manner, hard-RT delivery guarantees can be met across the whole protocol stack. The periodic

pattern of the time-aware schedule further matches the cyclic nature of the overarching manufacturing application.

When network nodes are clock-synchronized via IEEE 802.1AS, time-aware scheduling can be extended over multiple hops. IEEE 802.1AS therefore represents a prerequisite for time-aware scheduling

For the use cases defined in TR 22.803, resource reservation for hard-RT traffic typically spans time intervals between 500 $\mu$ s and 10ms.

IEEE 802.1Qbv also defines managed objects for Ethernet nodes to enable remote configuration of parameters associated with time-aware scheduling.

### **Frame Pre-emption**

Frame pre-emption defined by IEEE 802.1Qbu regulates the transport of lower-priority traffic in presence of time-aware schedules configured for hard-RT traffic. It introduces explicit solutions on Ethernet layer such as guard time intervals and frame interruption to circumvent the periodic traffic intervals reserved for hard-RT traffic. Frame pre-emption only considers resource partitioning in the time domain. It further assumes that lower layers lack autonomous frame-segmentation methods or are not aware of the time-interval boundaries configured.

### **Integration of 5G into high-performance manufacturing**

For incremental wireline-to-wireless migration in high-performance manufacturing, one can expect that individual wireline links or stars in the Ethernet network are replaced with 5G. From the perspective of the Ethernet network, the end-points of the 5G PDU-session align with the end points of the Ethernet link. Therefore, TSN specifications logically apply to the end-to-end PDU-session.

As Ethernet nodes support managed objects for the configuration of time-aware scheduling, the corresponding enhancements for the configuration of time-aware scheduling for 5G are necessary.



## 2.5.3 Mobile control with safety

(Mobile control panels with safety functions)

### 2.5.3.1 Description

- Safety control panels currently have mostly a wire-bound connection to the equipment they control. In consequence, there tend to be many such panels for the many machines and production units that typically can be found in a factory. With an ultra-reliable low-latency wireless link, it would be possible to connect such mobile control panels with safety functions wirelessly. This would lead to a higher usability and would allow for the flexible and easy re-use of panels for controlling different machines.
- One way to realize the safety functions is to make use of a special safety protocol, these safety protocols can ensure a certain safety level as specified with no or only minor requirements on the communication channel between the mobile control panel and the controlled equipment. To this end, a strictly cyclic data communication service is required between both ends. If the connectivity is interrupted, an emergency stop is triggered, even if no real safety event has occurred. That means the mobile control panel and the safety controller (e.g., a safety programmable logic controller [PLC]) it is attached to cyclically exchange messages and the machine stops if either the connection is lost or if the exchanged messages explicitly indicate that a safety event has been triggered (e.g., that the emergency stop button has been pushed). Thus, guaranteeing the required safety level is not difficult, but achieving at the same time a high availability of the controlled equipment/production machinery is. To that end, an ultra-reliable ultra-low-latency link is required.
- The cycle times for the safety traffic always depend on the process/machinery/equipment whose safety has to be ensured. For a fast-moving robot, for example, the cycle times are lower than for a slowly moving linear actuator.
- In general, this use case has very stringent requirements in terms of latency and service availability.

### 2.5.3.2 Source

- 3GPP SA1 TR 22.804 (Study on Communication for automation in vertical domains), see [15].

### 2.5.3.3 Pre-conditions

The mobile control panel with safety functions is connected to a safety PLC of the machine/equipment it is supposed to control. The mobile control panel is in a predefined geographical position related to the controlled device (defined area, free field of view). A cyclic data communication service matching the cycle time requirements of the used safety protocol has successfully been set up. The emergency stop button is not pushed. The panel is not operated in enabling device mode, i.e., the operator does not have to keep the enabling device switch in a dedicated stationary position for proper operation of the controlled equipment.

#### 2.5.3.4 Triggers

- Normal flow: the operator pushes the emergency stop button
- Alternative flow: the communication link between the panel and the machine is broken

#### 2.5.3.5 Normal Flow

A typical service flow may look as follows:

- The mobile control panel and safety PLC periodically exchange safety messages in intervals of  $T_{\text{cycle}}$  with a payload size of 40 bytes to 250 bytes, indicating absence of any safety event. The value of the cycle time  $T_{\text{cycle}}$  depends on the controlled equipment and some examples can be found in the requirements given below.
- In parallel, a non-cyclic bi-directional data communication service with a data rate of at least 5 Mbit/s in each direction is set up between the mobile control panel and the safety PLC for facilitating human interaction with the machine for configuring, monitoring, maintaining, etc. the machine.
- Various bursts of non-cyclic data traffic are exchanged between the mobile control panel and the safety PLC in parallel to the cyclic data communication service for the safety traffic.
- The operator pushes the emergency stop button on the control panel, triggering the transmission of corresponding safety messages to the safety PLC.
- The controlled machine stops within a pre-defined time.

#### 2.5.3.6 Alternative Flow

An alternative service flow covering the case of a broken link (which should be avoided) may look as follows:

- The mobile control panel and safety PLC periodically exchange safety messages in intervals of  $T_{\text{cycle}}$  with a payload size of 40 bytes to 250 bytes, indicating absence of any safety event. The value of the cycle time  $T_{\text{cycle}}$  depends on the controlled equipment and some examples can be found in the requirements given below.
- In parallel, a non-cyclic bi-directional data communication service with a data rate of at least 5 Mbit/s in each direction is set up between the mobile control panel and the safety PLC for facilitating human interaction with the machine for configuring, monitoring, maintaining, etc. the machine.
- Various bursts of non-cyclic messages are exchanged between the mobile control panel and the safety PLC in parallel to the enduring cyclic data communication service for the safety traffic.
- The cyclic data communication service between the mobile control panel and the safety PLC is interrupted or disturbed (in the sense that the cycle times requirement cannot be met anymore, for example), triggering a timeout at the safety PLC.
- The controlled machine stops within a pre-defined time.
- All messages exchanged have to be properly secured (especially data integrity and authenticity) and the probability of two consecutive packet errors shall be negligible. This

is because a single packet error may be tolerable, but two consecutive packet errors may lead to a false safety alarm and thus may lead to a lengthy production downtime.

#### 2.5.3.7 Post-conditions

Machines can be controlled in a safe way while meeting the requirements. The controlled machine has stopped within a pre-defined time after the emergency button has been pushed or the communication link was disturbed. Nobody got hurt.

#### 2.5.3.8 Potential Requirements

The 5G system shall support a bidirectional, cyclic data communication service characterised by at least the following parameters (e.g., for assembly robots or milling machines):

- Cycle time of  $T_{\text{cycle}} = 4 \text{ ms to } 8 \text{ ms}$
- Jitter  $< 50\%$  of cycle time
- Data packet size 40 byte to 250 byte
- Typical work space: 10 m x 10 m
- Parallel active safety services: max. 4 in a workspace

The 5G system shall support a non-cyclic bi-directional data communication service in parallel to the cyclic data transmission service with at least the following parameters:

- User experienced data rate  $> 5 \text{ Mbit/s}$
- Target end-to-end latency  $< 30 \text{ ms}$
- Jitter  $< 50\%$  of latency

The 5G system shall support a cyclic data communication service characterised by at least the following parameters (e.g., for mobile cranes, mobile concrete pumps, fixed portal cranes, etc.):

- Cycle time of  $T_{\text{cycle}} = 12 \text{ ms}$
- Jitter  $< 50\%$  of cycle time
- Data packet size 40 byte to 250 byte
- Typical work space: 40 m x 60 m
- Max. workspace: 200 m x 300 m
- Parallel active safety services: 2 in a workspace

The 5G system shall support an indoor positioning service within factory danger zones with horizontal positioning accuracy better than 1 m, [99.9%] availability, heading  $< 0,52 \text{ rad}$  and latency for positioning estimation of mobile device [ $< 1 \text{ s}$ ].

The 5G system shall support a communication service availability exceeding at least 99,9999%, ideally even 99,999999%.

The 5G system shall support an indoor positioning service for the rest of the factory hall with horizontal positioning accuracy better than [5 m], [90%] availability and latency for positioning estimation of mobile device  $< [5 \text{ s}]$ .

## 2.5.4 “All-Stop” in Mining and Construction Site Applications

### 2.5.4.1 Description

- An “All-Stop” is a special realization of emergency stop function (see ISO 13850 : 2015 - Safety of machinery - Emergency stop function - Principles for design), which stops connected assets within a certain range to the device in case of an emergency. This idea is currently discussed and developed by ISO TC 127 SC2 WG 22 (Autonomous Machine Safety).
- It is intended to be used predominantly on mine sites (e.g. open pit mining) – but would be applicable on all controlled workplaces where multiple interconnected vehicles interact and situations can get confusing.
- A basic example application would be a wearable push button given to workers that are able to command all machines within a certain range (depending on the application and the expected velocity of vehicles) to enter a safe state to anticipate accidents or prevent further damage when an accident has already happened.
- This would require that all machines present (independent of their brand) are able to interact with an “All-Stop” device, process the signal and react super-quickly (low latency). To function properly, machines must be able to localize themselves in relation to the “All-Stop” devices.
- Emergency stop function must at least fulfil the requirements of Performance Level ‘c’, acc. ISO 13850 : 2015 – this is comparable to Safety Integrity Level 1 acc. to ISO 61508 : 2011.
- Of course, the All-Stop could be improved by additional features like automatically establishing a connection to an emergency response team or visualizing the accident location to vehicles outside the safety range to help them avoid the area.

### 2.5.4.2 Source

- ISO TC 127 SC2 WG 22 – Autonomous Machine Safety

### 2.5.4.3 Roles and Actors

- Assuming an All-Stop would be realized by 5G (which is probably preferable because of the low latency guaranteed), the activation by an end-user of the wearable or machine-mounted push button would send a message across all interconnected assets on the site (operating autonomously, semi-autonomously or driven manually by other end-users), which have to localize themselves in relation to the activated All-Stop device and move to a safe state (for many applications, this is just seizing to operate) if they find themselves within the predefined safety range.

#### 2.5.4.4 Pre-conditions

- All machines need to be All-Stop capable – either by third-party aftermarket kits or as factory installed. The connectivity can be ensured by a site-owned 5G network, or by use of a public 5G network.

#### 2.5.4.5 Triggers

- An end-user pushes a wearable or machine-mounted All-Stop button.

#### 2.5.4.6 Normal Flow

- The activated All-Stop needs to communicate that it has been pushed, where it is currently localized. This information is shared via an electronic communications network within the closed group of connected site assets.

#### 2.5.4.7 Alternative Flow

- No.

#### 2.5.4.8 Post-conditions

- After the situation has been resolved, the machines that have entered a safe state must be manually re-started (autonomous machines must not re-start without human interaction, see ISO 13850 : 2016 and 2006/42/EC machinery directive).

#### 2.5.4.9 High Level Illustration

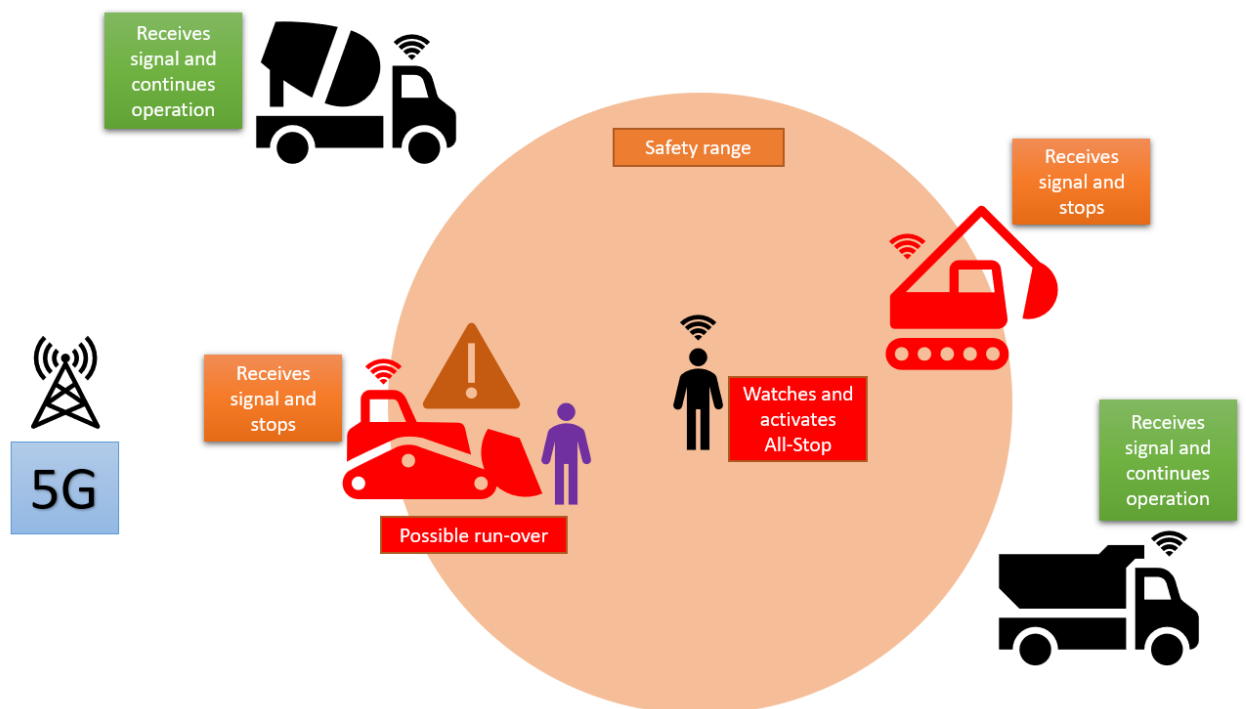

Figure 2-24: "All-Stop" in Mining and Construction Site Applications - High Level Illustration

#### 2.5.4.10 Potential Requirements

- Functional requirements:
  - Low latency (used in emergency situations)
  - High availability (the All-Stop provides a safety function)
  - Precise localization
- Non-functional requirements – possible consideration includes:
  - Flexibility (machines leaving and entering the site)
  - Scalability (depending on the site size)
  - Interoperability (machines of different brands need to interact)
  - Reliability (the All-Stop provides a safety function)

#### 2.5.4.11 Radio Specific requirements

##### 2.5.4.11.1 Radio Coverage

- **Radio cell range**

Depending on the site conditions, line-of sight can be more or less obstructed through height differences, large machines and structures, and the range requirements differ with the site size – full site coverage is needed for the All-Stop to be effective.

- **Is Multicell required?**

Depending on the site size, multiple cells might be necessary. Seamless handover is not necessary, as long as the network connection is quickly re-established.

- **Mobility:**

In mine site environments, haul trucks have a maximum travel speed of about 70 Km/h – on construction sites, vehicles typically move significantly slower.

- **Special coverage needs:**

No.

##### 2.5.4.11.2 Bandwidth requirements

- This application does not require a high data rate transmission.

##### 2.5.4.11.3 URLLC requirements

- **Required Latency** as short as technically possible<sup>2</sup>
- **Required Reliability** as high as technically possible<sup>3</sup>
- **Maximum tolerable jitter** N/A
- **Required localization accuracy** 1 m (easily achieved)

#### 2.5.4.11.4 *Radio regimens requirements*

- **Desired and acceptable radio regimens**

None.

#### 2.5.4.11.5 *Other requirements*

- **UE power consumption**  
Long life battery (wearable device), or supplied by the machine's battery powered supply network (mounted device)
- **Is terminal location required? Location accuracy?**  
Yes, in the meter range.

---

<sup>2</sup> ISO 13850 does not contain solid requirements for the time allowed to stop after the button has been pushed. The text reads: "The emergency stop function shall be so designed, that after actuation of the emergency stop device, hazardous movements and operations of the machine are stopped in an appropriate manner, without creating additional hazards and without any further intervention."

The 2006/42/EC machinery directive states the following: "Once active operation of the emergency stop device has ceased following a stop command, that command must be sustained by engagement of the emergency stop device until that engagement is specifically overridden; it must not be possible to engage the device without triggering a stop command; it must be possible to disengage the device only by an appropriate operation, and disengaging the device must not restart the machinery but only permit restarting. The emergency stop function must be available and operational at all times, regardless of the operating mode. Emergency stop devices must be a back-up to other safeguarding measures and not a substitute for them."

For practical reasons, the necessary latency can be derived from the human ability to react (~1000 ms) – it would be a reasonable assumption that the 1ms - 5ms provided by the 5G URLLC is more than enough.

<sup>3</sup> ISO 15817 : 2012 (Earth-moving machinery — Safety requirements for remote operator control systems) does not outline reliability requirements for remote stop functions. Preferable, an All-Stop would achieve Performance Level 'c' as outlined by ISO 13849-1 : 2015 (Safety of machinery - Safety-related parts of control systems - Part 1: General principles for design) and required by ISO 13850 : 2012 for emergency stops. Performance level 'c' translates in to an average probability of dangerous failure per hour (PFHd) in [1/h] below  $3 \times 10^{-6}$ , acc. ISO 13849-1 : 2015. If no other data exists, 50% of all failures are considered "dangerous". If the 99.9999% reliability is considered enough strongly depends on the application strategy in case of 5G downtime.

## 2.6 Smart Health

### 2.6.1 Intelligent Emergency Response Systems

#### 2.6.1.1 Description

- Various studies have concluded that falls in the home are the most common cause of injury among the elderly population, and one of the leading causes of morbidity and mortality among this population. There are several consequences of a fall in the elderly, including hip fractures, fear of falling and 'long lies', all of which could detrimentally affect both the psychological as well as physical wellbeing of the individual. A so called 'long lie' is a fall, in which the person remains on the ground for 5 min or more before being able to get up without assistance, or help arriving.

Automated fall detection systems are using worn fall detectors, which trigger an alarm, when both the orientation and acceleration forces of the person reach a pre-set threshold. Many different types of sensors can be used to detect a fall, e.g. mechanical sensors worn on either the hip or torso, vibration-based sensors placed on the floor or image-based sensors combined with artificial intelligence.

In case of an emergency detection, an alarm will be sent immediately to the emergency service center, possibly together with pictures or videos, which a camera being installed in the home has taken.

- In general, this use case has stringent requirements in terms of latency and service availability. When the fall detectors recognize an emergency case, a message must be sent immediately to the service center and a data streaming channel for transmitting the photos or videos be provided.

#### 2.6.1.2 Source

- Journal of Telemedicine and Telecare Volume 11 Number 4 2005, see [17].
- Technical Specification Group Services and System Aspects; Study on Communication Services for Critical Medical. 3GPP TR 22.826 V0.1.0, see [18].

#### 2.6.1.3 Roles and Actors

- Roles: Roles relating to/appearing in the use case
  - End user – person, who shall be protected from 'long lies'
  - Communication Network supplier
  - IoT platform provider
  - IoT device manufacturer
  - Operator of Intelligent Emergency Response System
  - Relationships between roles



#### 2.6.1.4 Pre-conditions

An automated fall detection system, which consists of worn fall detectors and camera(s) for taking photos or videos, must be installed in the living area to be supervised. A 5G connection between the detection system and the emergency service centre must be established. The emergency service centre has to be equipped with sufficient units to receive the alarms and data from the automated fall detection system and with educated staff to take appropriate actions for helping the person in danger.

In the event of a fall, the fall detector system has alerted the call centre but as they could not get him to respond they dispatched an ambulance. The ambulance must be equipped with devices for monitoring, examination and guided interventions like e.g. ultrasound probe, physiological signals monitors and, portable 4K smart glasses. Also, instant access to medical records is important to understand the patient's condition prior to the incident.

The Emergency Room (ER) and a local MNO have business contract in place by which the ER can ask the MNO (through suitable APIs) to allocate the necessary high priority resources fulfilling SLAs suitable to the transport of medical data (with special care taken on medical data integrity and confidentiality) to private geographical area covering the ambulance route and the site of the incident.

Each needed equipment (ultrasound probe, monitoring scopes, 5G enable 4k camera smart glasses ...) is:

- Powered up,
- Subscribed to 5G communication services fulfilling agreed SLAs,
- Attached to private slices deployed by the local MNO 5G network for the ER,
- Provisioned with parameters allowing establishment of a secure communication link to Connected to an authenticated application in the ER and/or hospital in charge of directing sharing incident data to with the authorized personnel

#### 2.6.1.5 Triggers

- Alarm signal sent to the Emergency centre from the automated fall detection.

#### 2.6.1.6 Normal Flow

The automated fall has sent an alarm and an emergency service has responded by sending an ambulance to assess how critical is the fall and if there is any internal bleeding.

1. The ambulance arrives to check for internal bleeding and to do this the ambulance doctor pulls out his portable Ultrasound-device (US-device), which directly starts streaming securely ultrasound-data (US-data) to the Emergency Room (ER) through a 5G communication service fulfilling agreed SLAs. This data is analysed by sonographer on call. The US-data is a 20fps 500x500 pixels 16 bits colour depth uncompressed image stream.

2. To allow the sonographer to provide optimal instructions on placing the US-probe, the ambulance doctor also streams live 4k video of the patient's broken hip through the 5G wireless camera mounted on his smart glasses. The video is 12 bits per pixel with 3840x2160 pixels, supports up to 60 fps and is compressed with lossy compression algorithm. Based on the video and US-streams, the sonographer provides instructions to ambulance doctor to move the US-probe to assess where the pain is located (as an option the sonographer can even control a robot in the ambulance for the ultrasound capture.). Interactions between sonographer and ambulance doc (incl. the 4k video stream and the return communication link) are supported by a second 5G communication service with suitable SLAs. Apart from moving, sonographer is able to control the operation of the US-device, e.g. to tune remotely the beam-forming parameters.
3. Seeing the ultrasound stream, the sonographer concludes its critical and internal bleeding has occurred that is also causing the heart rate to drop and an emergency is needed. The sonographer diagnose what is needed and the operation that needs to take place and informs the ambulance which hospital has the correct equipment for treatment and also informs the hospital that a patient is on its way.
4. Upon arrival at the hospital, the staff is waiting, the OR has been prepared and the patient is rushed there for immediate surgery. Resources assigned to communication services allocated to the Emergency Room are now released.

#### 2.6.1.7 Post-conditions

- The emergency service centre has taken appropriate actions either to send help to the person at need or to get the failed system back to operation.
- The 5G data connection is released and the automated fall detection system

#### 2.6.1.8 High Level Illustration

- High level figure/picture that shows the main entities used in the use case and if possible their interaction on a high level of abstraction

#### 2.6.1.9 Potential Requirements

The 5G system shall support simultaneous unicast transmission of one 100Mbps compressed 4k (3840x2160 pixels) 60Hz real time video stream and one uncompressed 80Mbps 500x500 pixels 20Hz real-time video stream for a communication service consuming resource from a PLMN.

The 5G system shall support a one way latency <5ms from source to a remote application for a communication service consuming resources from a PLMN.

The 5G system shall support a high communication service availability > 99,999% for real time video streams transporting medical data

The 5G system shall provide suitable APIs to allow use of a trusted 3rd party provided integrity protection mechanism for data exchanged with an authorized UE served by a 5G communication service.

- Non-functional requirements – possible consideration includes:
  - The 5G system shall be able to ensure the confidentiality and integrity of data for/from the remote fall detector and all devices in indirect communications.
  - All requirements related to security management in private network
  - The 5G system shall provide a mechanism for denial-of-service prevention.

## 2.7 Cross-vertical

### 2.7.1 Siemens White Paper “5G communication networks: Vertical industry requirements”

In [4], several 5G requirements were derived by Siemens based on their studies on vertical application domains, such as Smart City, Smart Mobility, Smart Manufacturing, Smart Energy and Smart Building.

Table 3 shows a consolidated view of the 5G requirements, while **Table 4** provides more details on the 5G requirements coming from verticals.

Table 3: 5G promises vs. Vertical requirements, copied from [4] with courtesy of Siemens

Category	Requirement	Explicit 5G promises (according to [1], Figure 2)	Consolidated requirements from verticals - Siemens view
Industry-grade Service Quality	Realtime capability – Latency	5 ms (e2e)	1 ms (local) 5 ms (long distance)
	Realtime capability – Jitter	-	1 us (local)
	Bandwidth	Peak data 10 Gbps Mobile data volume 10 TB/s/km <sup>2</sup> Number of devices: 1 mio/km <sup>2</sup>	kbps ... 10Gbps
	Time period of information loss during failures	-	none (seamless failover)
	Availability/coverage	-	ubiquitous
	Range (distance between communication neighbors)	-	0,1 m ... 200 km
	Reliability (minimum uptime per year [%])	99,999%	99,9999%
	Mobility	500km/h	500km/h
	Outdoor terminal location accuracy	<1m	0,1 m
	Multi-tenant support	yes (Network Slices)	yes
Operation and maintenance	Non-standard operating conditions	Energy consumption reduced by factor 10	<ul style="list-style-type: none"> <li>Battery powered devices with &gt;10years lifetime</li> <li>Harsh environments (weather, vibrations, heat, dust, hazardous gases, etc.)</li> </ul>
	Ease of use	-	<ul style="list-style-type: none"> <li>Communication services approach</li> <li>Plug and play device (sensor, actuator, controller) integration</li> </ul>
	SLA Tooling	-	Service Level Agreement (SLA) monitoring and management tools for provider and consumer
	Service deployment time (time between service request and service realization)	90 min	hours
	Private 5G infrastructures	-	yes
Non-technical	Scalability: Number of devices per km <sup>2</sup>	10 <sup>6</sup>	10 <sup>6</sup>
	Globally harmonized definition of Service Qualities	-	yes
	Technology availability	-	>20 years
	Globally simplified certification of ICT components	-	Yes
Assured Guarantees	-	-	mandatory

Table 4: 5G promises vs. Vertical requirements (details), copied from [4] with courtesy of Siemens

Category	Requirement	Explicit 5G promises (according to [1], Figure 2)	Siemens demand	Smart City	Smart Mobility	Smart Manufacturing		Smart Energy			Smart Building	
						Process	Discrete	Low Voltage	Medium Voltage	High Voltage		
Industry-grade Service Quality	Realtime capability – Latency	5 ms (e2e)	1 ms (local) 5 ms (long distance)	-	1 ms (local) 10 ms (long distance)	20ms (local) 1s (long distance)	1ms (local) 20ms (long distance)	-	25ms	5ms (long distance)	100ms	
	Realtime capability – Jitter	-	1us (local)	-	-	20ms	1us	-	25ms	1ms	-	
	Bandwidth	Peak data 10 Gbps Mobile data volume 10 TB/s/km <sup>2</sup> Number of devices: 1 mio/km <sup>2</sup>	kbps ... 10Gbps	kbps (sensors) ... Mbps (video supervision) ... 10 Gbps (data centers)	10 Mbps ... 1 Gbps	100 kbit/s (automation stream) ... 100 Mbps (remote access, video supervision)	100 kbit/s (automation stream) ... 100 Mbps (remote access, video supervision)	1 kbps per subscriber	5 Mbps per secondary substation	1Gbps along power lines	100 kbit/s (automation stream) ... 100 Mbps (remote access, video supervision)	
	Time period of information loss during failures	-	none (seamless failover)	1s	100 ms	100 ms	none (seamless failover)	minutes	25ms	none (seamless failover)	100 ms	
	Availability/coverage	-	Ubiquitous	City-level	Ubiquitous	Industrial Plant Areas	Industrial Plant Areas	Ubiquitous	Ubiquitous	Ubiquitous	City-level	
	Range (distance between communication neighbors)	-	0,1 m ... 200 km	10 km	1 km (cars) ... 10 km (trains)	0,1m ... 10 km	0,1 m ... 100 m	10 km	20 km	200 km	100m	
	Reliability (minimum uptime per year [%])	99,999%	100%	99,9%	100%	100%	100%	98%	99,9%	100%	99,9%	
	Mobility	500km/h	500km/h	100km/h	500km/h	50km/h	50km/h	5km/h	-	-	5km/h	
	Outdoor terminal location accuracy	<1m	0,1 m	1 m	0,1 m	0,1 m	0,1 m	10 m	10 m	-	0,1 m	
	Multi-tenant support	yes (Network Slices)	yes									
Operation and maintenance	Non-standard operating conditions	Energy consumption reduced by factor 10	<ul style="list-style-type: none"> <li>Battery powered devices with &gt;10years lifetime</li> <li>Harsh environments (weather, vibrations, heat, dust, hazardous gases, etc.)</li> </ul>									
	Ease of use	-	<ul style="list-style-type: none"> <li>Communication Services approach</li> <li>Plug and Play Device (Sensor, Actuator, Controller) integration</li> </ul>									
	SLA Tooling	-	Service Level Agreement (SLA) monitoring and management tools for provider and consumer									
	Service deployment time (time between service request and service realization)	90 min	hours									
private 5G infrastructures	-	yes	-	yes	yes	yes	-	optional	yes	optional		
Non-technical	Scalability: Number of devices per km <sup>2</sup>	10 <sup>4</sup>	10 <sup>5</sup>	10 <sup>5</sup>	10 <sup>4</sup>	10 <sup>5</sup> (high density of devices)	10 <sup>5</sup> (high density of devices)	10 <sup>4</sup>	10 <sup>3</sup>	10 <sup>3</sup>	10 <sup>5</sup>	
	Globally harmonized definition of Service Qualities	-	yes	-	yes	yes (for long distance)	yes (for long distance)	-	yes	yes	-	
	Technology availability	-	>20 years									
	Globally simplified certification of ICT components	-	Yes									
Assured Guarantees	-	Mandatory	Relaxed	Mandatory	Mandatory	Mandatory	Mandatory	Relaxed	Mandatory	Mandatory	Relaxed	

## 2.7.2 Tactile Internet Use Case

### 2.7.2.1 Description

- The objective is to enable ultra-high reliability and ultra-low latency applications over networks that may fully, partially or not support the requirements. Meeting these requirements enables a class of applications where the network is part of a (haptic) feedback loop. Such networks have been called the Tactile Internet.
- Examples include Remote Human Machine Interfaces, and coordinating multiple vehicles moving at high speeds at a close distance.

### 2.7.2.2 Roles and Actors

- All facets of the network contribute to the end-to-end latency, so there are many opportunities to improve the latency. However, large opportunities can be found in the following roles:
  - The physical layer design
  - The wireless connection between device and router
  - The routing protocol in the access network

### 2.7.2.3 Pre-conditions

The network support for small bursts of packets and large amount of bandwidth is required, both in the last mile and core network.

### 2.7.2.4 Triggers

- Service request and service setup.

### 2.7.2.5 Normal Flow

- Mostly End-to-End, devices in one end to the actuators in the other end.
- The network traffic resources are to be guaranteed before the use case.

### 2.7.2.6 Alternative Flow

- None

### 2.7.2.7 Post-conditions

- Release of the resources.

### 2.7.2.8 High Level Illustration

Tactile Internet, at a basic level, should support haptic communications, i.e., the network should deliver physical haptic experience across the network (requiring ultra-low-latency and ultra-high-reliability). Such a network will not only add a new dimension to the current set of immersive applications (e.g., online virtual-reality based network games), but will also enable truly real-time human-machine interactive applications. Some examples are, remote surgery on a patient located hundreds of miles away; delivering the skillset of a trained person to operate heavy machinery remotely, and platooning and coordinating a fleet of vehicles moving at high speeds.

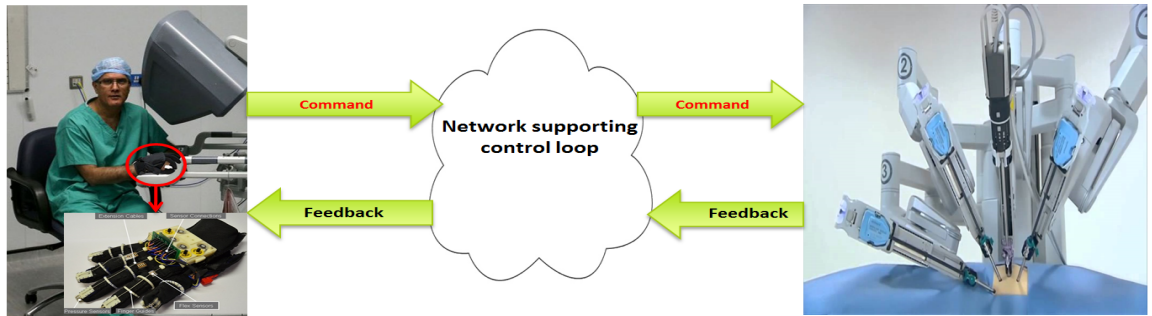

Figure 2-25 Example of depicting the vision of the Tactile Internet

While Cyber-Physical Systems (CPS) realized controlling machines and physical parameters autonomously over the Internet, Tactile Internet is taking this vision to the next step, i.e., enabling the immersive bidirectional human-machine and/or human-physical world interaction. The next generation of cyber physical systems that will be a part of the Tactile Internet has the potential to literally touch every aspect of our lives. An example is shown in Figure 2-25, wherein a doctor is performing surgery on a patient who may be miles away. The gloves and virtual reality system supports the doctors by giving real-time feel and the robot hand provides necessary haptic feedback. If this application is to be supported, we need Tactile Internet since all the remote surgeries performed these days are within a very short distance taking the advantage of sophistication in surgical instruments.

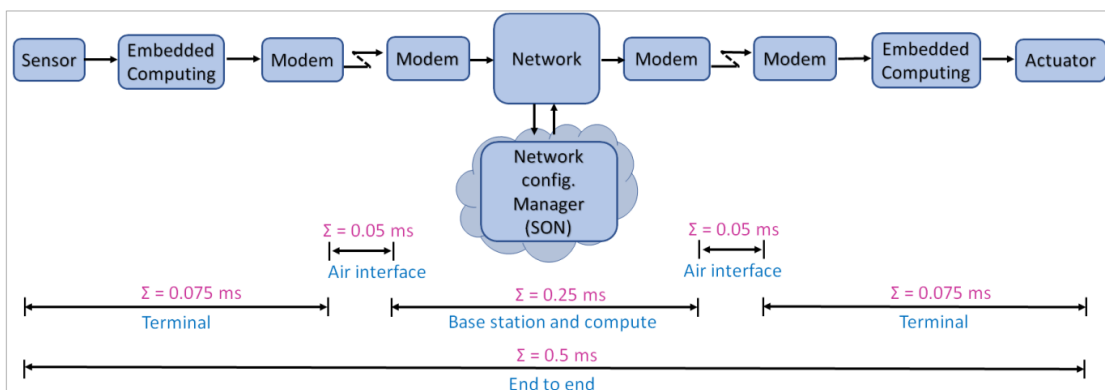

Figure 2-26: Tactile Internet latency requirement

The human sensation of touch requires a temporal resolution of 1000 Hz for a good perceptual experience. This leads to round-trip latency of 1 ms as one of the grand challenges of Tactile Internet. In Figure 2-26, a possible distribution of the delays across the network elements is shown. While these numbers seem attractive to enable real-time haptic communication, they may also seem far-fetched. The 1 ms round-trip latency can be achieved only for distances less than 150 km due to the physical limit (speed of light). However minimum reaction time for humans is in the order of tens of ms. Therefore, a more pragmatic view must be taken while keeping the long-term ambition of Tactile Internet of revolutionizing remote haptic applications. One of the important steps in realizing the tactile

Internet is to find the balance and feasibility of current technology but still try to reach 1ms roundtrip delay. Haptic feedback is key requirement for high-performance and experience interaction, allowing the local and remote users to grasp the objects in the virtual environments via the sense of touch and feel. The sensors/actuators, computation, connectivity and cognition processing provide for sensitive object manipulations to perform remote tele-surgery, micro-assembly or related applications requiring reliable and high levels of sensitivity and precision.

Intelligence is enabled through mobile edge computing and embedded at the application level, e.g. automation, robotics, telepresence, augmented reality, virtual reality and digital twins for real-time manufacturing and autonomous systems.

**2.7.2.9 Potential Requirements**

The requirements for this use case can be split in:

- Functional requirements

Type	Burst size	Latency([ms])	Reliability	Average data rate
Haptics sensor (position, velocity, angular velocity)	For single DoF:2-8B  (depending on number of sensors)	<10 (highly dynamic)  <100 (medium)	99.999 – 99.99999	1000/s sensor data packets/s
Haptic feedback (forces, torques, vibration, etc.)	Similar	<10 (highly dynamic)  <100 (medium)	99.99-99.999	Similar
Audio (AR)	~50 B	10-50 (Highly Dynamic)  Up to 150 (static)	99 (with FEC)	128-256kbps (for stereo voice)
Video (AR)	~1.5 KB	same	99.9 (with FEC)	~1Mbps (depends on pixel size)

- Non-functional requirements – possible consideration includes:
  - Flexibility
  - Scalability
  - Interoperability
  - Reliability
  - Safety
  - Security and privacy
  - Trust

## 2.7.2.10 Radio Specific requirements

### 2.7.2.10.1 Radio Coverage

- **Radio cell range**

Usually constrained to indoor or customer premises?

- Is Multicell required?
  - NO

### 2.7.2.10.2 Bandwidth requirements

- Peak data rate: 8kB per sensor; ~1.5MBps (for video+Audio)
- Average data rate : 8kB per sensor; ~1.5MBps (for video+Audio)
- Is traffic packet mode or circuit mode?
  - Packet mode

### 2.7.2.10.3 URLLC requirements

- Required Latency
  - <10ms
- Required Reliability
  - (i.e. 99,99999%)
  - Maximum tolerable jitter

### 2.7.2.10.4 Radio regimens requirements

- Desired and acceptable radio regimens
  - *licensed - public mobile*
  - *license-exempt: in case of last mile Femto cell implementations*

### 2.7.2.10.5 Other requirements

- UE power consumption
  - Rechargeable or primary battery
- Is terminal location required? Location accuracy?
  - Indoors room level

## 2.7.3 Holographic Meetings

### 2.7.3.1 Description

- The objective is to enable to make users at long distances to interact with each other. The current Internet is not capable of transporting the highly reliable as well as low latency applications. Further to this touch sensitivity can be added. Meeting these requirements enables a class of applications that are immersive and real feel which is better than VR communications.
- Examples include immersive AR remote interactions.



### 2.7.3.2 Source

- Work in progress at TUD (Technical University Delft, the Netherlands)

### 2.7.3.3 Roles and Actors

- All facets of the network contribute to the end-to-end latency, so there are many opportunities to improve the latency. However, large opportunities can be found in the following roles (which are similar to Tactile Internet applications):
  - The physical layer design
  - The wireless connection between device and router
  - The routing protocol in the access network
  - Small packets need to be transported in large numbers.

Note: If touch is not supported, then the requirement for latency and reliability can be slightly relaxed compared to TI applications.

### 2.7.3.4 Pre-conditions

The network support for small bursts of packets and large amount of bandwidth is required, both in the last mile and core network.

### 2.7.3.5 Triggers

- Service request and service setup (as that of video calls)

### 2.7.3.6 Normal Flow

- Mostly End-to-End, camera in one end to the projectors in the other end.
- The network traffic resources are to be guaranteed before the use case.

### 2.7.3.7 Alternative Flow

- None

### 2.7.3.8 Post-conditions

- Release of the resources.

### 2.7.3.9 High Level Illustration

The following figure provides a simple illustration.



Figure 2-27: Two persons interacting over a network feeling real meeting

Holographic interactions will be the next frontier in immersive interactions using new communication technologies. This application could be enhanced by using Tactile Feedback. At the least, this application needs high speed communication and carry the facial expressions and movements in 3D. It requires low-latency and high-reliability. This application will add a new dimension to the current set of immersive applications. The next level would be to add the composition of human skillsets to be transferred while providing audio, visual & haptic feedback.

### 2.7.3.10 Potential Requirements

The requirements for this use case can be split in:

- Functional requirements

Type	Burst size	Latency([ms])	Reliability	Average data rate
Haptics sensor (position, velocity, angular velocity) Both ways.	For single DoF:2-8B (depending on number of sensors)	<10 (highly dynamic) <100 (medium)*	99.99 w/o compr – 99.999 w compr	2kB-8kB/s sensor data packets/s w/o compression 200-800B/s w compr
Haptic feedback (forces, torques, vibration, etc.)	Similar	<10 (highly dynamic) <100 (medium)*	Similar	Similar
Audio (AR)	~100 B	<10 (Highly Dynamic) Up to 150 (static)*	99.9 99* (with Forward Error correction)	2-512kbps (for stereo voice)
Video (AR)	~100kB*	Same	99.999 99.9* (with Forward Error correction)	1-100Mbps (depends on pixel size)

All other numbers are taken from [44]; \*Are estimates from work in progress at TUD (Technical University Delft, the Netherlands)

Note: The provided functional requirements apply to this use case (Holographic Interaction Use case) and are based on experimentation done in controlled environments (lab experiments).

Non-functional requirements – possible consideration includes:

Flexibility

- Scalability
- Interoperability
- Reliability
- Safety
- Security and privacy
- Trust

### **2.7.3.11 Radio Specific requirements**

#### **2.7.3.11.1 Radio Coverage**

- Radio cell range

Usually constrained to indoor or customer premises?

- Is Multicell required?

No

#### **2.7.3.11.2 Bandwidth requirements**

- Peak data rate: 8kB per sensor; ~1.5MBps (for video+Audio)
- Average data rate: 8kB per sensor; ~1.5MBps (for video+Audio)
- Is traffic packet mode or circuit mode?

Packet mode

#### **2.7.3.11.3 URLLC requirements**

- Required Latency  

<10ms
- Required Reliability  

(i.e., 99,99999%)
- Maximum tolerable jitter

#### **2.7.3.11.4 Radio regimens requirements**

- Desired and acceptable radio regimens
  - licensed - public mobile
  - license-exempt: in case of last mile Femto cell implementations

#### 2.7.3.11.5 Other requirements

- UE power consumption
  - Rechargeable or primary battery
- Is terminal location required? Location accuracy?
  - Indoors room level

### 3 Emerging Topics

This section describes emerging topics that are related to IoT and can impact the specifications and deployments of 5G. Those emerging topics are:

1. *Tactile Internet of Things*
2. *ETSI ITS G5 versus LTE-V2X*
3. *5G Non-public Networks and Network Slicing*
4. *Overview of the 'Green Deal'*
5. *IoT and 5G frequency spectrum*
6. *5G promise towards the evolving energy sector*

### 3.1 Tactile Internet of Things

The tactile IoT/IIoT is a shift in the collaborative paradigm, adding sensing/actuating capabilities transported over the network to communications modalities, so that people and machines no longer need to be physically close to the systems they operate or interact with as they can be controlled remotely. Tactile IoT/IIoT combines ultra-low latency with extremely high availability, reliability and security and enables humans and machines to interact with their environment, in real-time, using haptic interaction with visual feedback, while on the move and within a certain spatial communication range. Faster internet connections and increased bandwidth allow to increase the information garnered from onsite sensors within industrial IoT network. This requires new software and hardware for managing storing, analysing and accessing the extra data quickly and seamlessly through a tactile IoT/IIoT applications. Hyperconnectivity is needed to take VR and AR to the next level for uniform video streaming and remote control/tactile internet (low latency) [20].

Tactile IoT/IIoT is bringing intelligent connectivity (convergence of IoT/IIoT, 5G, and AI) at the edge using ultra low latency (less than 1ms), ultra-high reliability (99.999% availability) communication allowing human-to-machine (H2M) and machine-to-machine (M2M) collaboration and co-existence into a new knowledge-centric environment.

A round-trip latency of 1ms in conjunction with carrier-grade robustness and availability will enable the tactile IoT for steering and control of real and virtual objects [34].

Tactile IoT could increase the differences between machines and humans by building on the areas where machines are more performant and humans are less effective, the machines are more likely to complement humans rather than substitute for them. The value of human inputs could grow, not shrink, as the power of machines increases and peer economy companies are examples of innovations that increase the value of human labour rather than reducing it [35].

Automation, robotics, telepresence, augmented reality, virtual reality and digital twins for real-time applications and autonomous systems are becoming key technologies in industrial applications for remote operation of industrial machinery. The tactile IoT enables the efficient manufacturing of highly customised products, remote control in high-risk areas, and remote inspection, maintenance and repair across various industrial sectors and applications.

Tactile IoT provides the cyber/virtual environment for remote physical interaction in real-time needed to exchange closed-loop information/knowledge among virtual and/or real objects/things (i.e., humans, machines, processes and experiences) at the edge.

The tactile Internet presents acutely challenging requirements, in terms of latency, reliability, security, and likely others such as the density of users, devices and links. The tactile Internet is also highly multi-disciplinary, requiring consideration of aspects outside of the scope of communications technology. While there is broad standardization of 5G technology ongoing under the efforts of the 3GPP, IEEE, ETSI and others, which aim to set the structures in place

to realize a range of challenging applications, there are not standards addressing the multi-disciplinary nature of the tactile Internet or considering the precise challenging mix of requirements that the tactile Internet enables. There are standardization activities addressing Tactile Internet defined as "a network or network of networks for remotely accessing, perceiving, manipulating or controlling real or virtual objects or processes in perceived real time by humans or machines" in the working group IEEE P1918.1 [19].

The tactile IoT enables haptic interaction with visual feedback through sense and touch, by using perception and manipulation of objects/things at the edge. The visual feedback encompasses audio/visual/sensing interaction and robotic sensing/actuating that can be controlled in real-time.

For real-time autonomous and remote-controlled systems to match human interaction with their environment, they need to meet the speed of natural reaction times. As a round-trip of less than 1ms end-to-end latency is required for tactile IoT applications, the connectivity network must be ultra-reliable as many critical tasks are executed remotely and it must rely on efficient intelligent edge infrastructure in order to enable scale.

The implementation of tactile IoT requires the convergence of multiple technologies, at the network, application level and at the edge where the tactile IoT is enabled by the intelligent IoT devices and robotic things.

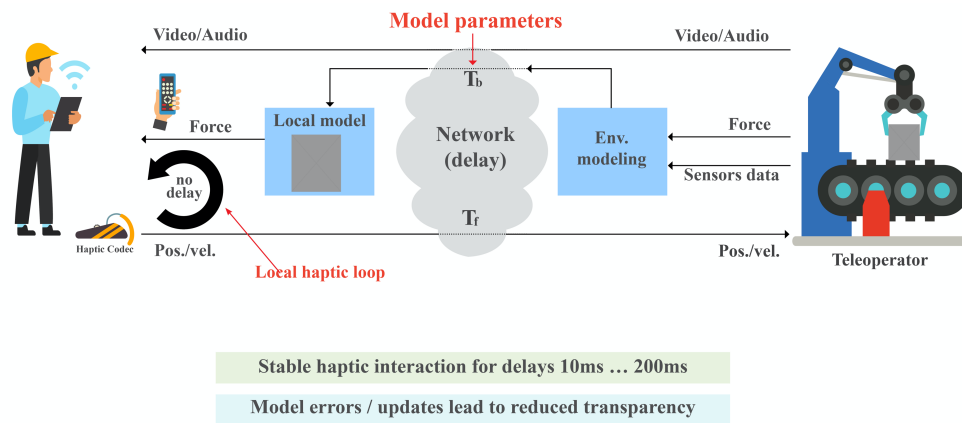

Figure 3-1 Tactile IoT model (Source: adapted from Prof Ekehard Steinbach, TU Munich)

Information exchange is bi-directional and usually closes a global control loop (haptic vs. non-haptic control). The tactile IoT feedback loop includes three domains: master/device domain, network/connectivity domain and slave/controlled/actuated domain.

The master domain controls the remote operation of the actuated domain and consists of a human/operator/machine and a human/machine interface that converts the human/machine input into a tactile input using audio/visual/haptic feedbacks.

The network/connectivity domain provides the connectivity medium for bi-directional information/knowledge exchange between master/device and slave/controlled/actuated domains. The network/connectivity domain need to match the key technical requirements of latency, ultra-reliability and data transmission. It is expected that 5G networks will enable the

tactile IoT implementation at the wireless edge and the features such as network slicing, enabled by NFV/SDN, will provide the required design and distributed architecture flexibility.

The slave/controlled/actuated domain interacts with various objects/things in the remote environment using audio/visual/haptic feedbacks integrated into an intelligent sensor/actuator remote system.

## 3.2 ETSI ITS G5 versus 3GPP LTE-V2X (based on EC H2020 AUTOPILOT project)

There are two key technologies considered today for intelligent transportation systems, namely ITS-G5 and Cellular-V2X (C-V2X).

ITS-G5 and C-V2X are rooted in totally different design principles, leading to fundamentally different radio interfaces, although they have many commonalities at higher layers and can largely share the same protocol stack above the PHY/MAC radio layers.

ITS-G5 is specified by ETSI and its radio air-interface is based on Wi-Fi-like IEEE 802.11p (also known as DSRC in the US), whereas C-V2X is specified by 3GPP. The current realization of C-V2X is LTE-V2X for short range and long range communications, while 5G NR-V2X is the future realization of C-V2X.

Both ITS-G5 and C-V2X are primarily intended for the delivery of warnings for driver assistance functionalities (SAE level 1 and 2), rather than for fully autonomous (self-driving) vehicles. V2X communication via ITS-G5 or C-V2X extends the line-of-sight-limited operation of sensors such as cameras, radars and LIDAR.

### ITS-G5

ITS-G5 is designed for short range radio communications between vehicles (V2V) and between vehicles and road side infrastructure (V2I), and is based on the Wi-Fi-like 802.11p specifications which were standardized by IEEE in 2004-2009. An ITS-G5 signal uses OFDM and is designed to occupy a 10 MHz channel in the license exempt 5.9 GHz band (harmonized for ITS in Europe). The MAC layer of ITS-G5 is based on a Wi-Fi-like carrier sense multiple access (CSMA) protocol with random back off to allow statistical sharing of the medium among multiple stations in a distributed manner.

ITS-G5 supports short range communications (several hundred meters) with low latency (~2 ms under light traffic conditions) and high reliability, and works in high vehicle speed mobility conditions. ITS-G5 operates independently of cellular network coverage.

A group in IEEE has begun to investigate enhancements of the 802.11p technology (referred to as new generation V2X) for future more advanced services such as autonomous driving. The group is working in the project called P802.11bd [36] to develop the Project Authorization Request (PAR), Criteria for Standard Development (CSD) and TGBd Definitions and Requirements for an enhanced V2X technology while keeping backward compatibility with 802.11p.

### C-V2X

LTE-V2X is today's realization of C-V2X and was standardized in 3GPP Release 14 in March 2017. LTE-V2X supports both short range and long range communications.

LTE-V2X short range mode (PC5) supports communications between vehicles (V2V), between vehicles and road side infrastructure (V2I), and between vehicles and pedestrians (V2P) or other vulnerable road users. The LTE-V2X short range mode signal uses OFDMA and



occupies a 10 MHz channel in the license exempt 5.9 GHz band (harmonized for ITS in Europe). Its MAC layer is based on semi-persistent scheduling and allows deterministic sharing of the medium among multiple stations in a distributed manner. LTE-V2X short range mode operates independently of (and does not require the availability of) cellular networks. LTE-V2X short range mode and ITS-G5 are direct substitutes, while LTE-V2X has been shown in recent tests<sup>4</sup> to have a superior performance in range/link-budget (reliability).

LTE-V2X long range mode (Uu) supports communications between vehicles and the base stations of a cellular LTE network (V2N). The standard was largely built on previous 3GPP LTE releases (Releases 8-13) with specific enhancement for V2N links. LTE-V2X long range mode is intended for operation in bands licensed for cellular mobile networks, and has already been used for delivery of services such as traffic jam warnings, weather condition warnings, road hazard warnings, etc. LTE-V2X long range mode benefits from the huge investments made in nationwide LTE cellular mobile networks in recent years.

5G-V2X is the future realisation of C-V2X and will be able to enable more advanced safety services, such as those which might be required for autonomous vehicles. Standardisation of 5G-V2X is on-going in 3GPP with already a first step completed with Release 15 in June 2018, and a second step Release 16 expected to be finalized in December 2019. C-V2X has a forward compatible evolution path to 5G NR-V2X which provides lower latency, ultra-reliable communication and high data rate for autonomous driving.

Note that ITS-G5 is not an equivalent substitute for LTE-V2X for delivering C-ITS priority services. ITS-G5 cannot match the performance of LTE-V2X in direct short-range communications, and does not support long-range communications at all. Nor can ITS-G5 achieve the level of implicit compatibility between LTE-V2X and 5G-V2X, due to the fundamentally different technological and design principles in the specifications of IEEE 802.11p (ITS-G5) and 3GPP C-V2X (LTE-V2X/5G-V2X).

LTE-V2X is the natural pre-cursor to 5G-V2X from the perspectives of both design and industrial ecosystem, and the combination of these two C-V2X technologies can allow for the most cost-effective deployment of C-ITS services in the European Union.

### **Regulatory landscape in Europe**

In Europe the traffic control requirements are currently defined through C-ITS platform Phase II that will cover the deployment and operation of C-ITS [22][23].

The EU is preparing a Delegated Act for C-ITS (Cooperative Intelligent Transport Systems) defining how the communication between vehicles and with the roadside infrastructure should be carried out [21]. This will regulate V2X communication and place requirements on C-ITS stations for the delivery of several specific C-ITS priority services (e.g. dangerous situation warnings, road works warnings, signalised intersections, etc.), as well as security and privacy issues.

The current draft Delegated Regulation excludes all technologies other than ITS-G5; i.e., excludes 3G and 4G (LTE-V2X) cellular networks for long-range communications and LTE-V2X for short range communications. At the time of writing, a public consultation on the

---

<sup>4</sup> <http://5gaa.org/news/5gaa-report-shows-superior-performance-of-cellular-v2x-vs-dsrc/>

Delegated Regulation has just ended, with a large number of responses<sup>5</sup> from industry and administrations, with many supporting the inclusion of 3G/4G and LTE-V2X in the Regulation.

Spectrum regulations in Europe are technology neutral. As such, both ITS-G5 and LTE-V2X can operate in the 5.9 GHz band (harmonised in Europe for ITS) subject to compliance with the ETSI harmonised standard EN 302 571, as required by the relevant ECC and EC Decisions<sup>6</sup>.

In order to avoid harmful co-channel interference, ITS-G5 and LTE-V2X can simply deploy in different 10 MHz channels at 5.9 GHz. Special technical measures (time sharing protocols) are required to allow ITS-G5 and LTE-V2X to operate in the same channel. ETSI has been tasked to develop such techniques in response to a mandate<sup>7</sup> from the EC to CEPT. However, the technical feasibility of such techniques, and the timelines for availability of solutions is as yet uncertain.

It is worth noting recent developments in the United States, where having supported DSRC (802.11p) for many years, the US Department of Transportation has acknowledged the rapid advances in technology vis-à-vis C-V2X and is now advocating a market-led approach for the preferred solution for V2X communication<sup>8</sup>.

Furthermore, in November 2018 China published regulations<sup>9</sup> for Intelligent Connected Vehicles in the 5.9 GHz band, mandating the use of LTE-V2X.

The cellular V2X technology has two operational modes which, between them, cover most eventualities. One has low-latency C-V2X direct communications over the PC5 interface on the 5.9GHz band and is designed for active safety messages such as immediate road hazard warnings and other short-range V2V, V2I, and V2P situations. This mode aligns closely with what's offered by the ITS-G5 technology, which also uses the 5.9GHz band. The other mode has communications over the air interface (Uu) on the regular licensed-band cellular network and can handle V2N use cases like infotainment and latency-tolerant safety messages concerning longer-range road hazards or traffic conditions. IEEE 802.11p can only match this mode by making ad hoc connections to roadside base stations, since the protocol does not make use of cellular connectivity.

---

<sup>5</sup> [https://ec.europa.eu/info/law/better-regulation/initiatives/ares-2017-2592333/feedback\\_en?size=10&p\\_id=351850](https://ec.europa.eu/info/law/better-regulation/initiatives/ares-2017-2592333/feedback_en?size=10&p_id=351850)

<sup>6</sup> ECC Decision (08)01, and Commission Decision 2008/671/EC.

<sup>7</sup> RSCOM17-26 rev.3 (Final)

<sup>8</sup> Heidi King, Deputy Administrator NHSTA, "Spectrum and Connectivity in supporting Transportation Safety," Keynote remarks at the International Symposium on Advanced Radio Technologies 2018 Conference," July 25, 2018. <https://www.nhtsa.gov/speeches-presentations/prepared-keynote-remarks-international-symposium-advanced-radio-technologies>

<sup>9</sup> <http://www.miit.gov.cn/n1146290/n4388791/c6483506/content.html>, <http://en.silkroad.news.cn/2018/1116/119878.shtml>

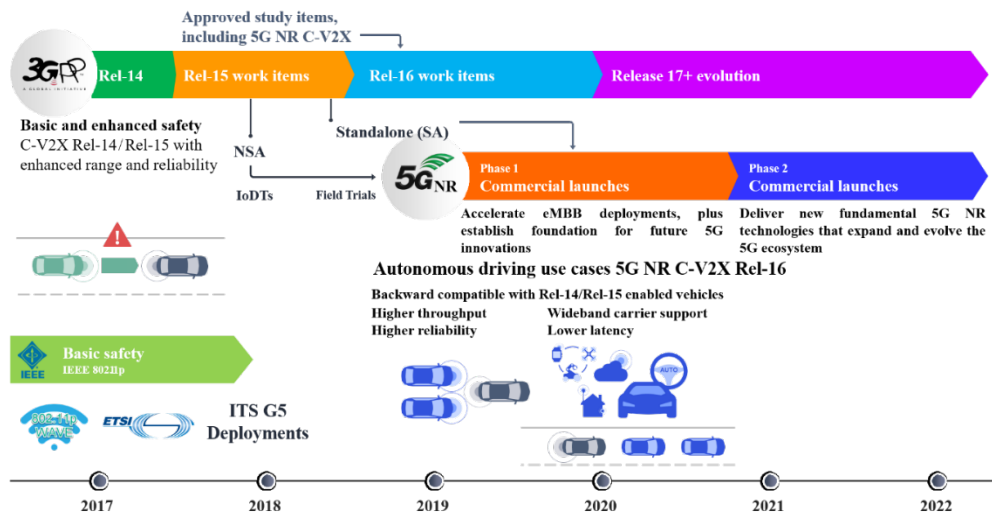

Figure 3-2: Roadmap for development and deployment of V2X and C-V2X technologies, based on 3GPP and [EC H2020 AUTOPILOT project](#)

Next generation technologies using different frequency bands (e.g. high-frequency (e.g. 60GHz), high-bandwidth mmWave, etc.) could be incorporated in the 5G V2X access network architecture to support specific V2X use cases to maximize the benefits for the vehicle users. The frequency bands to be used by 5G NR-V2X are still under discussion at 3GPP. The roadmap for development and deployment of V2X and C-V2X technologies is presented in Figure 3-2.

The autonomous vehicle communication covers several domains as presented in Figure 3-3 including V2X (i.e. V2V, V2I, V2N) that will be covered by 5G.

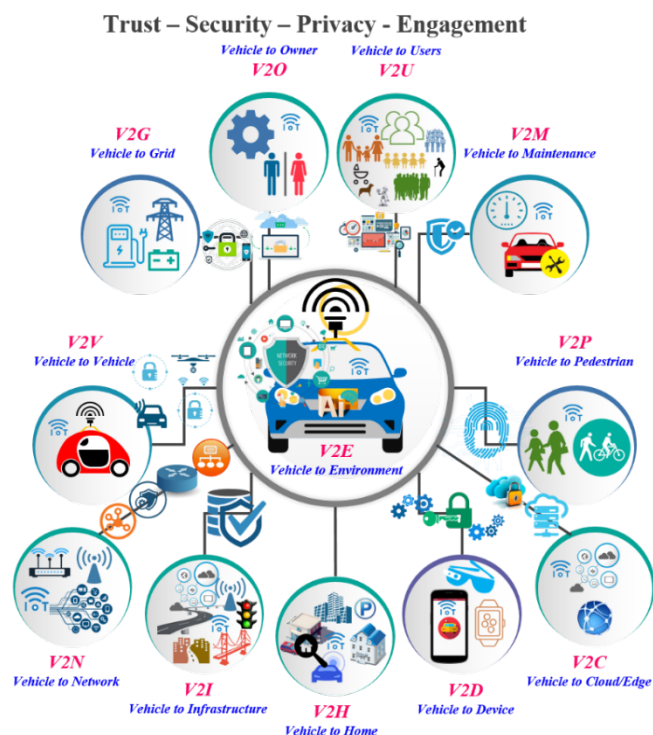

Figure 3-3: Autonomous vehicle domains of interaction and communication channels, based on [EC H2020 AUTOPILOT project](#)

Table 5 outlines the 5G performance requirements for different scenarios as described in [30]. All the values in this table are targeted values and not strict requirements.

Table 5: Target 5G performance requirements, based on [30]

Scenario	Experienced data rate (DL)	Experienced data rate (UL)	Area traffic capability (DL)	Area traffic capacity (UL)	Overall user density	Activity factor	UE speed	Coverage
Urban macro	50 Mbps	25 Mbps	100 Gbps/km <sup>2</sup> (Note 4)	50 Gbps/km <sup>2</sup> (Note 4)	10000 per km <sup>2</sup>	20 %	Pedestrians and users in vehicles (up to 120 km/h)	Full network (Note 1)
Rural macro	50 Mbps	25 Mbps	1 Gbps/km <sup>2</sup> (Note 4)	0,5 Gbps/km <sup>2</sup> (Note 4)	100 per km <sup>2</sup>	20 %	Pedestrians and users in vehicles (up to 120 km/h)	Full network (Note 1)
Indoor hotspot	1 Gbps	500 Mbps	15 Tbps/km <sup>2</sup>	2 Tbps/km <sup>2</sup>	250000 per km <sup>2</sup>	Note 2	Pedestrians	Office and residential (Note 2, 3)
Broadband access in a crowd	25 Mbps	50 Mbps	[3,75] Tbps/km <sup>2</sup>	[7,5] Tbps/km <sup>2</sup>	[500000] per km <sup>2</sup>	30 %	Pedestrians	Confined area
Dense urban	300 Mbps	50 Mbps	750 Gbps/km <sup>2</sup> (Note 4)	125 Gbps/km <sup>2</sup> (Note 4)	25000 per km <sup>2</sup>	10 %	Pedestrians and users in vehicles (up to 60 km/h)	Downtown (Note 1)
Broadcast like services	Maximum 200 Mbps (per TV channel)	N/A or modest (e.g. 500 kbps per user)	N/A	N/A	[15] TV channels of [20 Mbps] on one carrier	N/A	Stationary users, pedestrians and users in vehicles (up to 500 km/h)	Full network (Note 1)
High speed train	50 Mbps	25 Mbps	15 Gbps/Train	7,5 Gbps/Train	1000 per Train	30 %	Users in trains (up to 500 km/h)	Along railways (Note 1)

High speed vehicle	500 Mbps	25 Mbps	[100] Gbps/km <sup>2</sup>	[50] Gbps/km <sup>2</sup>	4000 per km <sup>2</sup>	50 %	Users in vehicles (up to 250 km/h)	Along roads
Airplane connectivity	15 Mbps	7,5 Mbps	1,2 Gbps/Plane	0,6 Gbps/Plane	400 per Plane	20 %	Users in airplanes (up to 1000 km/h)	(Note 1)
<p>NOTE 1: For users in vehicles, the UE can be connected to the network directly, or via an on-board moving base station.</p> <p>NOTE 2: A certain traffic mix is assumed; only some users use services that require the highest data rates [31].</p> <p>NOTE 3: For interactive audio and video services, for example, virtual meetings, the required two-way end-to-end latency (UL and DL) is 2-4 ms while the corresponding experienced data rate needs to be up to 8K 3D video [300 Mbps] in uplink and downlink.</p> <p>NOTE 4: These values are derived based on overall user density. Detailed information can be found in [32].</p>								

### 3.3 5G Non-public Networks and Network Slicing

3GPP mobile networks (GSM, 3G, 4G) so far have been mainly designed and deployed as public networks offering mobile phone and broadband services to the consumer market. 5G mobile networks are targeting new application areas beyond this traditional consumer centric mobile phone business. In addition to enhanced mobile broadband services (eMBB), massive machine type communication (mMTC) and ultra-reliable and low latency communication (URLLC) services are of special interest to business customers from various domains like manufacturing, farming, mobility, energy grids, programme making and special events (PMSE). Such customers have specific and demanding requirements concerning service availability, reliability, latency, location, management, flexibility and QoS. They are not sufficiently supported by current public mobile networks where the network resources are shared by all participants. With 5G the option of dedicated non-public mobile networks becomes available. Furthermore network slicing promises to allow to assign network resources on top of a common infrastructure for specific services and customers, thereby providing specific service guarantees. Network slicing can be used on both public and non-public 5G networks.

It should be noted that the specifications for 5G are still under development. The currently finalized first 5G release (release 15 of 3GPP) focuses on eMBB services. mMTC and URLLC service will be supported by later releases starting from release 16. The detailed functionality for example for network slicing is therefore currently not defined. Furthermore the availability of specific functionality and features depends on the implementation plans of equipment providers and deployment decisions of network service providers.

#### 3.3.1 5G non-public networks

Non-public mobile networks use dedicated network infrastructure. While in principle it is possible to use non-public networks in license exempt spectrum bands like the 2.4 GHz ISM band, the full advantage of non-public wireless networks comes only to play when dedicated non-shared spectrum is used. License exempt spectrum is shared by many radio technologies and services and coexistence of these services has to be ensured which negatively impacts for example QoS and service availability.

Radio spectrum assignment is in the responsibility of countries and is done by the communication network regulator of a country like the FCC in the United States and BNetzA in Germany. Dedicated spectrum for a specific service is usually allocated country wide, and for public mobile networks it is assigned to service providers in order to provide a country wide mobile radio service to the general public. Such assignments usually involve huge license costs and/or specific requirements concerning the time line of the role out and the country wide coverage. Non-public networks often require only a very small coverage area like a factory, a campus, a stadium or an event area. The same spectrum can therefore be used by many non-public networks that are geographically dispersed. The assignment of radio spectrum for 5G services is currently ongoing in many countries. BNetzA has assigned the spectrum from 3.7 to 3.8 GHz for local and regional services. The specific details on how to apply for the spectrum, how the assignment is performed and related costs are still open.

The network infrastructure for non-public 5G networks can be installed, owned and operated by the user of the network itself (e.g. factory owner). It is usually part of an overall network at the specific location (e.g. a factory network) which may include wireline communication technologies like Ethernet and other wireless technologies like WLAN. The user can control and manage the whole network end-to-end including the 5G part and has therefore full control of QoS, latency, security, privacy, availability and reliability. He can roll out the network at the time, with the functionality and with the coverage as needed. However, that comes with the costs for the network infrastructure and operation and requires strong expertise in mobile network technologies and operation.

Non-public networks can also be provided and/or operated by a service provider who is contracted by the user.

### 3.3.2 5G network slicing

5G network slicing allows to have multiple virtual networks on top of a single physical 5G network infrastructure. This includes both the core network and the radio access network (RAN) part. The Network operator can assign dedicated network resources for these virtual networks in order to provide the specific service requirements and functionality required by the customer. With network slices, different service types from best effort communication to a large number of IoT devices to low latency and high bandwidth services for robots and medical imaging can be supported on the same network. It allows to share the network infrastructure between public and non-public network services. On a non-public network infrastructure, services for specific applications and stakeholders can be introduced with network slicing.

In order to use network slicing, the network infrastructure has to be available and has to support network slicing. Furthermore, the network infrastructure has to be ready to support the customer requirements. This may include the support of dedicated radio interfaces and measures for increased availability of network services. Also the coverage needed by the customer has to be supported, which may require the installation of additional base stations for example in a factory. All this leads to additional investments in the network infrastructure.

If non-public network services shall be provided via the network infrastructure of a public network operator the customers are heavily bound to the business decisions of the public network operator, like network deployment (where and when), service offerings and costs. A factory that needs URLLC services could not operate until such services are offered by public network operators. Farming and special events companies often demand wireless communication for a short time frame of hours and days at remote locations (e.g. harvest, sports event). Public network operators must be ready to provide such flexibility. In comparison dedicated 5G non-public networks can be deployed as needed by the user, assuming that the required spectrum is available. Availability and reliability are very important for example for factory networks as the standstill of a production line can lead to high costs. They therefore prefer full control of the network resources and their operation. Furthermore companies have security and privacy concerns when essential parts of their communication network (e.g. shop floor network of a factory) are hosted by 3rd parties.

### 3.4 Overview of the 'Green Deal'

Parts of this section were included in the SNS partnership proposal that were submitted to the European Commission on the 3rd of March 2020, by a joint contribution coming from 5GIA, AIOTI, Networld2020, CISPE and NESSI.

On 11 October 2019, the European Commission published the [European Green Deal](#) presenting a list of [policy initiatives](#) aimed at driving Europe to reach net-zero global warming emissions by 2050. The goal of the European Green Deal is to improve the well-being of people by making Europe climate-neutral and protecting Europe’s natural habitat for the benefit of people, planet and economy. The European Green Deal targets that the EU needs to fulfil are, see Figure 1:

- reach climate neutrality by 2050
- protect human life, animals and plants by cutting pollution
- help become world leaders in clean products and technologies
- help ensure a just and inclusive transition

Some of the reasons for motivating the initiation of the European Green Deal are<sup>10</sup>:

- 93 % of Europeans see a climate change as a serious problem
- 93 % of Europeans have taken at least one action to tackle climate change
- 79 % agree that taking action on climate change will lead to innovation

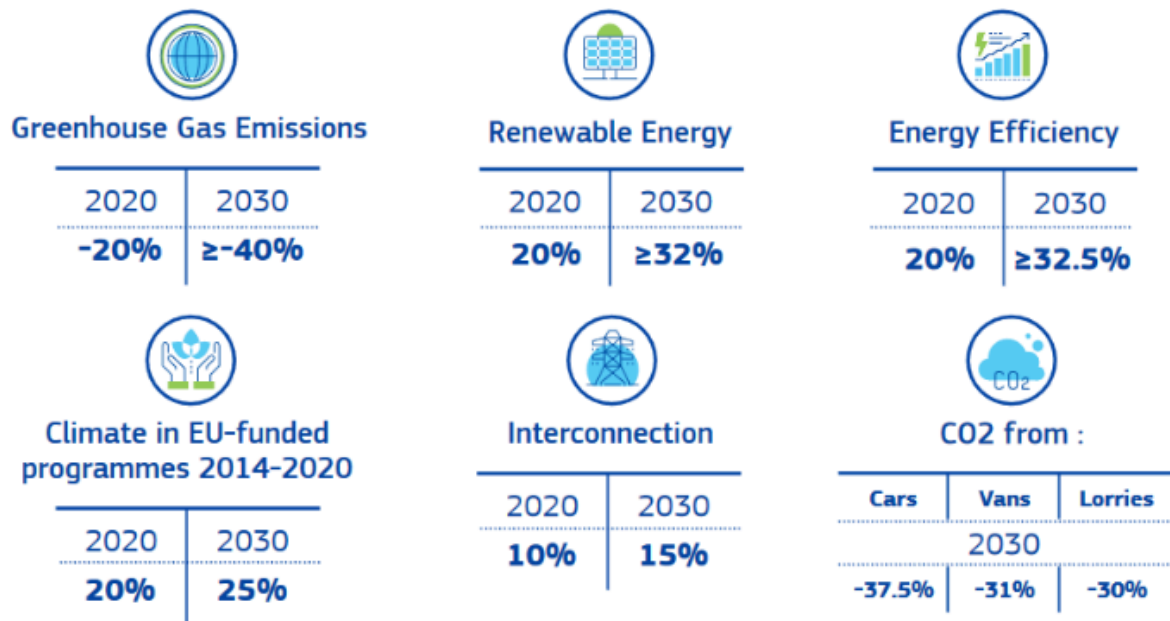

Figure 3-4: EU-Energy and Climate Targets 2018/2019 / Source: [European Commission 2019](#)

<sup>10</sup> [https://ec.europa.eu/commission/presscorner/api/files/attachment/859152/What\\_is\\_the\\_European\\_Green\\_Deal\\_en.pdf](https://ec.europa.eu/commission/presscorner/api/files/attachment/859152/What_is_the_European_Green_Deal_en.pdf)



One of the key objectives of AIOTI could be to launch activities on realising (a subset of) the Europe's Green Deal objectives described below.

### 3.4.1 Climate neutral Europe

The EU aims to reach net-zero greenhouse gas emissions by 2050, an objective that will be endorsed in a 'Climate Law' to be presented in March 2020. In particular, the reductions in the GHG (Greenhouse Gas) emissions compared to 1990 are:

- -20 % in 2020 - 2023: EU member states update their national energy and climate plans to reflect the new climate ambition
- -50 – 55 % in 2030
- No net emissions of greenhouse gases in 2050, see [43]

The proposed objectives to realise these targets are:

- Interconnect energy systems while integrating and increasing share of renewable energy sources into the grid
- Promote and integrate innovative technologies and modern infrastructure
- Boost energy efficiency and eco-design of products
- Decarbonise the gas sector and promote smart integration across sectors
- Empower consumers and help Member States to tackle energy poverty
- Increase cross-border and regional cooperation to better share clean energy sources
- Promote EU energy standards and technologies at global level
- Promote support for citizen dialogues and support of energy communities

### 3.4.2 Sustainable industry and Circular economy

In March 2020, a new circular economy action plan will be launched as part of a broader EU industrial strategy that will include a sustainable product policy with "prescriptions on how we make things" in order to prioritise reducing and reusing materials before recycling them. Moreover, the minimum requirements will be set to prevent environmentally harmful products from being placed on the EU market. False green claims will be tackled. The first efforts are targeted to focus first on resource intense sectors such as: textiles, construction, electronics and plastics.

In order to achieve the EU's climate and environmental goals requires a new industrial policy based on the circular economy. Some mentioned figures are:

- From 1970 to 2017, the annual global extraction of materials tripled, and it continues to grow.
- More than 90 % of biodiversity loss and water stress come from resource extraction and processing.
- EU's industry accounts for 20 % of the EU's emissions.
- Only 12 % of the materials used by EU industry come from recycling.

Europe needs a digital sector that puts sustainability and green growth at its heart. In particular, digitalisation presents new opportunities for:

- monitoring of air and water pollution,
- monitoring and optimising how energy and natural resources are consumed.

### 3.4.3 Buildings renovation and retrofitting

The reason of focusing on this objective is due to the fact that 40 % of European's energy consumption is by buildings. The main focus will be to renovate buildings, to help people cut their energy bills and energy use.

The proposed objectives to accomplish better energy performance of buildings are:

- Prices of different energy sources should incentivize energy-efficient buildings
- Design of buildings should be in line with the circular economy
- Increased digitalization
- More climate-proofing of buildings
- Strict enforcement of rules on energy performance of buildings

### 3.4.4 Eliminating pollution

Whether in air, soil or water, the objective is to reach a "pollution-free environment" by 2050.

The following objectives are proposed to reduce pollution:

Clean water:

- Preserve biodiversity in our lakes, rivers and wetlands.
- Reduce pollution from excess nutrients thanks to the Farm to Fork strategy.
- Reduce particularly harmful pollution from micro-plastics and pharmaceuticals.

Clean air:

- Review air quality standards in line with the World Health Organization guidelines.
- Protect citizens against dangerous chemicals with a new chemical strategy for sustainability for a toxic-free environment.
- Combine better health protection with increased global competitiveness.
- Reduce pollution from large industrial installations.
- Provide support to local authorities to achieve cleaner air for our citizens

Industry

- Reduce pollution from large industrial installations.
- Improve prevention of industrial accidents

## Chemicals

- Protect citizens against dangerous chemicals with a new chemical strategy for sustainability for a toxic-free environment.
- Combine better health protection with increased global competitiveness.
- Reduce pollution from large industrial installations.
- Provide support to local authorities to achieve cleaner air for our citizens.
- Develop more sustainable alternatives.
- Improve rules on assessment of substances launched on the market.

### 3.4.5 Ecosystems & biodiversity

In March 2020 a new biodiversity strategy will be presented in the run-up to a UN biodiversity summit taking place in China in October.

The EU targets to:

- Lead by example, through the European Green Deal
- Use diplomacy, trade and development cooperation to advance climate action
- Set standards for sustainable growth across global value chains.

The uptake of the planned eco-schemes and shift of the focus from compliance to performance towards improved environmental and climate performance, including managing and storing carbon in the soil, and improved nutrient management to improve water quality and reduce emissions is expected to increase the demand for the enabling technologies as well as foster innovation within the sustainable practices, such as precision agriculture, organic farming, agro-ecology, agro-forestry and stricter animal welfare standards and potentially sustainable seafood as a source of low-carbon food.

### 3.4.6 Farm to fork strategy

In the spring 2020, the new farm to fork strategy will be launched that will aim for a “green and healthier agriculture” system. The target is to make sure that Europeans get:

- affordable and sustainable food
- tackle climate change
- protect the environment
- preserve biodiversity
- increase organic farming

The European Commission will work with Member States and stakeholders to realize the following objectives:

- Ensure the transition is fair and just for everyone working in the European agricultural and maritime sector;
- Reduce significantly the dependency, risk and use of chemical pesticides, as well as of fertilizers, antibiotics;

- Develop innovative farming and fishing techniques that protect harvest from pests and diseases.
- Farm to fork will also help combat food fraud by preventing, detecting and fighting it through coordination with Member States and non-EU countries.
- Imported food products from third countries must comply with the EU's environmental standards.

### 3.4.7 Sustainable mobility

According to the European Green Deal, Europe must reduce emissions from transport further and faster. Transport accounts for a quarter of the European Union's greenhouse gas emissions and these continue to grow. Therefore, the Green Deal seeks a 90 % reduction in these emissions by 2050.

Some of the objectives of realising the Sustainable mobility Green Deal targets are:

Go digital

- Automated mobility and smart traffic management systems will make transport more efficient and cleaner.
- Smart applications and 'Mobility as a Service' solutions will be developed.
- Use different modes of transport
  - more freight should be transported by rail or water
  - the Single European Sky should significantly reduce aviation emissions at zero cost to consumers and companies.
- Boost supply of sustainable alternative transport fuels

By 2025, about 1 million public recharging and refuelling stations will be needed for the 13 million zero- and low-emission vehicles expected on European roads.

- Reduce pollution
  - The Green Deal will address emissions, urban congestion, and improve public transport, which can be realized by:
    - stricter standards on pollution by cars
    - to reduce pollution in EU ports
    - to improve air quality near airports

### 3.4.8 R&D and innovation

It is considered that the Horizon Europe research and innovation program will also contribute to the Green Deal during the next seven years (2021 - 2027). In particular, it is planned that 35 % of the EU's research funding will be set aside for climate-friendly technologies under an agreement struck earlier this year. Moreover, a series of EU research "moonshots" will focus chiefly on environmental objectives.

### 3.5 IoT and 5G frequency spectrum

The IoT technologies are developing, and new connectivity protocols and frequency bands are used for implementing the functions provided by IoT/IIoT communication/network layer. New connectivity based on 5G technologies are expected to support applications such as smart homes and buildings, smart cities, 3D video, remote medical services, virtual and augmented reality and massive machine-to-machine communications for industrial automation.

5G networks are expected to support the new IoT technologies, enabling IoT/IIoT device producers to develop and deploy new IoT devices and systems across multiple industries and provide IoT/IIoT applications globally.

The following references are used as input to this section: [37], [38], [39], [40], [41], [42].

To implement the ultra-low latency and very high bit-rate applications, the connectivity technologies require more sizable contiguous blocks of the spectrum than those available in frequency bands that have been previously used. As the IoT/IIoT and the underlying connectivity technologies aim for worldwide coverage, there is a need for harmonised worldwide bands in order to facilitate global roaming and the benefits of economies of scale.

5G technologies support various requirements such as enhanced mobile broadband (eMBB), massive machine-type communications (mMTC), and ultra-reliable low-latency communications (URLLC) as illustrated in Figure 3-5.

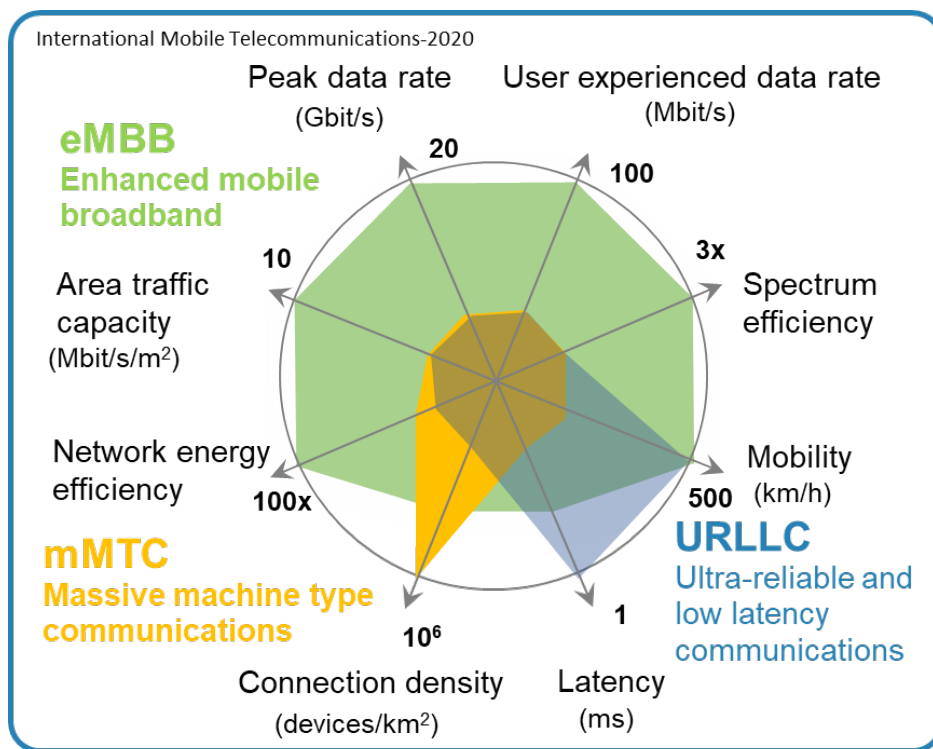

Source: Recommendation ITU-R M.2083

Figure 3-5: 5G technologies heterogeneous requirements

The frequency spectrum is a crucial factor driving 5G deployment as the spectrum management agencies assign the rights to individual users, telecommunication technology providers, broadcasters, industrial stakeholders, etc.

The 5G technologies need new harmonised mobile spectrum and regulators should aim to make available 80-100 MHz of contiguous spectrum in 5G mid-bands (i.e. 3.5 GHz) and around 1 GHz per operator in millimetre wave bands (i.e. 26/40 GHz).

The 5G technologies spectrum is distributed within three key frequency ranges to deliver the required coverage and support different use cases across various applications. The three ranges are: below-2 GHz, 2-6 GHz and above 24 GHz as presented in Figure 3-6.

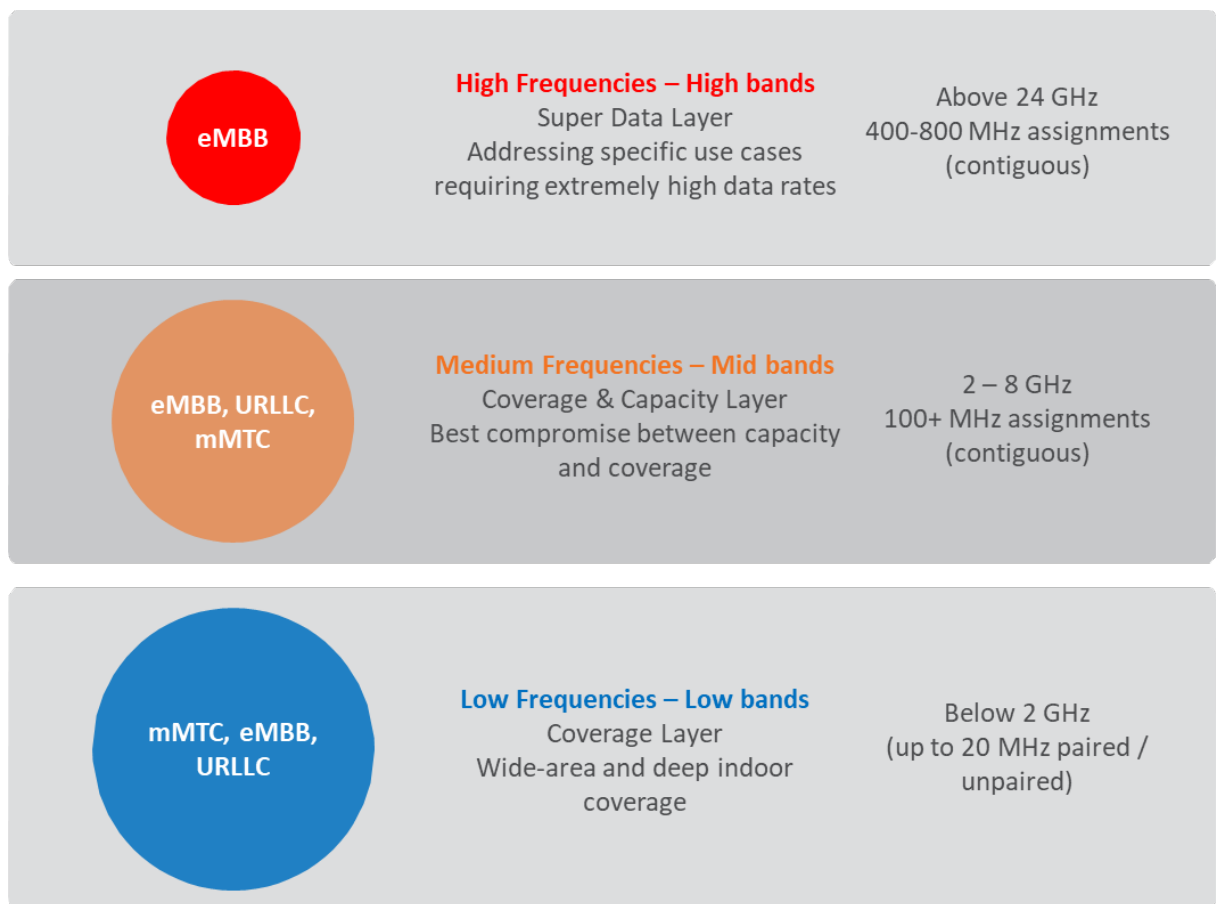

Figure 3-6: Three ranges of the frequency spectrum for 5G technologies

Below-2 GHz low frequencies – low bands, support widespread coverage across urban, suburban and rural areas and accelerate the IoT services for massive machine-type communications. Low-frequency bands extend the 5G mobile broadband to more extensive areas and deeper indoor environments. URLLC and mMTC type services benefit from enhancing coverage at the low frequency-bands.

The 2-8 GHz medium frequencies – mid bands offer a mixture of coverage and capacity benefits that includes spectrum within the 3.3-3.8 GHz range expected to form the base for many 5G services. The mid bands include the 2.3 GHz and 2.6 GHz frequencies. The unpaired (TDD) bands at 3300-4200, 4400-5000, 2500-2690 and 2300-2400 MHz deliver the best compromise between wide-area coverage and high capacity.

Above 24 GHz high frequencies – high bands are needed to ensure the ultra-high broadband speeds. The 26 GHz and/or 28 GHz bands have the most international support in this range. High-frequency bands are essential for providing additional capacity and delivering the extremely high data rates required by some 5G eMBB applications at specific locations (“hotspots”). The 400-800 MHz of contiguous spectrum per network operator is recommended from higher frequencies to achieve good return on investment and meet service requirements.

The 5G spectrum targets worldwide and spectrum frequencies for global harmonisation are presented in Figure 3-7.

	< 1GHz	3GHz	4GHz	5GHz	24-28GHz	37-40GHz	64-71GHz
<b>US</b>	600 MHz (2x35 MHz)	2.5 GHz (LTE B41)	3.55 - 3.7 GHz 7 - 4.2 GHz	5.9 - 7.1 GHz	24.25 - 24.45 GHz 24.75 - 25.25 GHz 27.5 - 28.35 GHz	37 - 37.6 GHz 37.6 - 40 GHz 47.2 - 48.2 GHz	64 - 71 GHz
<b>Canada</b>	600 MHz (2x35 MHz)				27.5 - 28.35 GHz	37.5 - 37.6 GHz 37.6 - 40 GHz	64 - 71 GHz
<b>EU</b>	700 MHz (2x30 MHz)		3.4 - 3.8 GHz		24.25 - 27.5 GHz	40.5 - 43.5 GHz	66 - 71 GHz
<b>UK</b>	700 MHz (2x30 MHz)		3.4 - 3.8 GHz		26 GHz		
<b>Germany</b>	700 MHz (2x30 MHz)		3.4 - 3.8 GHz		26 GHz		
<b>France</b>	700 MHz (2x30 MHz)		3.46 - 3.8 GHz		26 GHz		
<b>Italy</b>	700 MHz (2x30 MHz)		3.6 - 3.8 GHz		26.5 - 27.5 GHz		
<b>China</b>		3.3 - 3.6 GHz		4.8 - 5 GHz	24.5 - 27.5 GHz	37.5 - 42.5 GHz	
<b>South Korea</b>		3.4 - 3.7 GHz			26.5 - 29.5 GHz		
<b>Japan</b>		3.6 - 4.2 GHz	4.4 - 4.9 GHz		27.5 - 29.5 GHz		
<b>Australia</b>		3.4 - 3.7 GHz			24.25 - 27.5 GHz	39 GHz	

**Figure 3-7: Global 5G Spectrum – Allocated or targeted frequency bands around the world**

The frequency bands 24.25-27.5 GHz (global), 37-43.5 GHz (global), 45.5-47 GHz (regional/multi-country), 47.2-48.2 GHz (regional/multi-country) and 66-71 GHz (global) were identified for International Mobile Telecommunications (IMT) for the deployment of 5G networks, see Figure 3-8. This frequency band grouping was agreed by the World

Radiocommunication Conference 2019 (WRC-19), which took place in Egypt, 28 October to 22 November 2019. WRC-19 took measures to ensure appropriate protection of the Earth Exploration Satellite Services, including meteorological and other passive services in adjacent bands.

Group 30 (GHz)	Group 40 (GHz)	Group 50 (GHz)	Group 70/80 (GHz)
24.25-27.5 31.8-33.4	37-40.5 40.5-42.5 42.5-43.5	45.5-47 47-47.2 47.2-58.2 50.4-52.6	66-71 71-76 81-86

Figure 3-8: Frequency bands identified by the WRC-19 for the deployment of 5G networks

WRC-19 identified 17.25 GHz of the spectrum, in comparison with 1.9 GHz of bandwidth available before the conference. Out of this number, 14.75 GHz of the spectrum has been harmonized worldwide, reaching 85% of global harmonization.

The availability of additional mid-band spectrum was a priority for several regional organizations and groups of countries at WRC-19. As a result, the Conference reached the following consensus on [Resolution COM6/1 \(WRC-19\)](#) which includes the following mid-band related agenda items for the WRC-23:

“1.2 to consider identification of the frequency bands 3 300-3 400 MHz, 3 600-3 800 MHz, 6 425-7 025 MHz, 7 025-7 125 MHz and 10.0-10.5 GHz for International Mobile Telecommunications (IMT), including possible additional allocations to the mobile service on a primary basis, in accordance with Resolution COM6/2 (WRC-19);”

Furthermore, according to Resolution [COM6/2 \(WRC-19\)](#):

“...resolves to invite ITU-R...

2) to conduct and complete in time for WRC-23 the sharing and compatibility studies, with a view to ensuring the protection of services to which the frequency band is allocated on a primary basis, without imposing additional regulatory or technical constraints on those services, and also, as appropriate, on services in adjacent bands, for the frequency bands:

- 3 600-3 800 MHz and 3 300-3 400 MHz (Region 2);
- 3 300-3 400 MHz (amend footnote in Region 1);
- 7 025-7 125 MHz (globally);
- 6 425-7 025 MHz (Region 1);
- 10 000-10 500 MHz (Region 2),”



The agreed agenda item requires studies to understand the possibilities to deploy IMT while protecting existing services in the band. Based on the results of such studies, national administrations will be able to take informed decisions on the future availability of the band for IMT.

The combination of favourable propagation characteristics and the opportunity for wide channelization makes the 6 GHz band uniquely well suited for IMT. The band will offer much higher capacity than low bands and better coverage than millimetric-wave spectrum.

WRC-19 also proposed a plan of studies to identify frequencies for 5G technologies facilitating mobile connectivity by High Altitude IMT Base Stations (HIBS) where HIBS can be used as a part of terrestrial IMT networks to provide mobile connectivity in areas that are challenging to be covered by ground-based IMT base stations at a reasonable cost.

### 3.6 5G promise towards the evolving energy sector

The 5G communication technology can be as well applied in evolving Energy sectors. The following focus areas can be identified:

- Sector coupling: electrification of mobility sector; flexibility
- Evolving technologies, such as digital twins within the system of system nodes
- Smart grids;

The promise of 5G in Energy is stretched between seamless and unified interface offering multi-Gigabit speeds and sub-millisecond latency, supporting distributed architectures and the intelligent edge.

The anticipated ultra-high speeds for enhanced broadband, the ultra-low latency for mission-critical applications and massive internet of things for devices integration if coupled with low power needs, high coverage and fast deployment

The context of the 5G application in Energy touches upon every system of system nodes as presented by ETIP-SNET VISION 2050, and depicted in Figure 3-9. There are overarching topics, such as climate change adaptation, system resilience, including rare event management and **sector coupling** (gas, heat, green hydrogen, other fuels). Sector coupling can be applied in a multi-energy system, where investment in one system may be divided over other connected sectors, decreasing CAPEX per sector and at the same time, widening scenarios of investment decisions to alternative solutions in the cross-energy system which can become more economical. For example, the storage of energy within the electric system, e.g., hydro, batteries, can be conveniently replaced by storing energy in other forms, such as thermal, synthetic gases.

Each node and interface will have its connectivity requirements and needs, while orchestration across the nodes and sectors will introduce an additional vector of complexity with add on of evolving technologies, such as **digital twins** within the system of system nodes.



Figure 3-9: System of System approach VISION2050

The rapidly evolving electrification of mobility sector and the related services are influencing the need for flexibility management within the mobility and energy sectors in a synchronised and coordinated way.

Expanding decentralisation due to the evolving energy communities, technologies, including smart energy components, such as distributed storage and greater penetration of the renewable technologies give rise to the flexibility management enablement need that can connect, monitor, automate and control demand and supply side of nodes and the system overall.

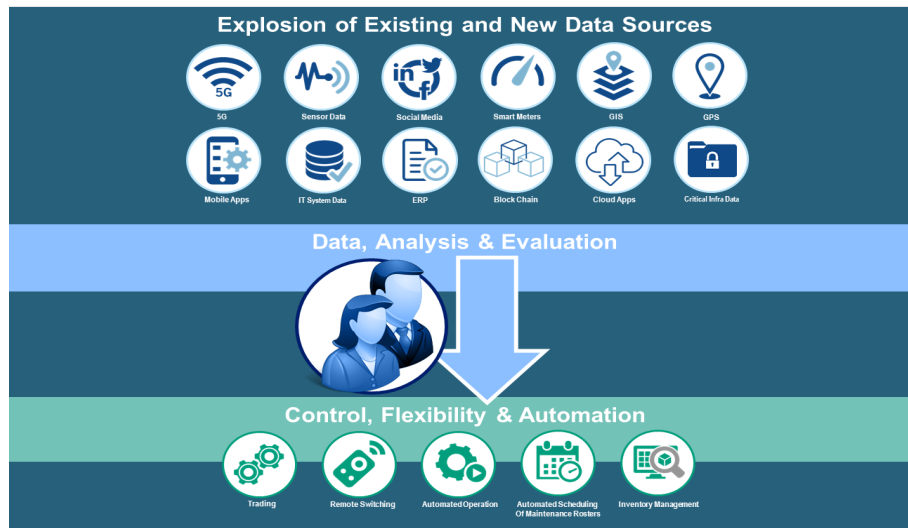

Figure 3-10 New data sources in distribution grid operator's networks

Another area of assets management is within energy infrastructures and critical nodes, such as a smart substation, reaching to the smart meters. The **smart grid** paradigm is heavily dependent on the reliable, secure, resilient and ubiquitous network. 5G can support the proliferation of smart grids while enabling smart energy components, see Figure 3-10.

The automation and control needs are well documented in the work of [ETIP SNET Working Group 1](#) paper <sup>11</sup> On Holistic Architectures in the Energy sector. The “integration of distributed generation and the extreme volatile nature of the new renewable energy sources (wind, solar) require a high automation degree of power systems and customers... Digitalisation is necessary, overall, to enable the active participation of customers, electricity producers and storage operators into the market.”

### 3.6.1 Requirements for Smart Grids - Convergence between electric distribution and communication infrastructures.

The new features and greater efficiency of smart grids can be enabled due to greater accuracy, higher numbers of connected devices resulting in more significant forecasting across nodes. Smart cities can better balance the energy load while reducing electricity peaks while striving to achieve lower energy costs and CO2 impact.

The **Sector coupling** needs are beyond mobility are documented in the recent [ETIP-SNET WG 1 paper](#)<sup>12</sup> on energy storage “Sector coupling has recently gained increased attention, bringing new complexity into infrastructure investment decisions but also new opportunities for its **smart operation**.”

In the evolving system with sector coupling, it is expected that grid and system operators “shall have many and sophisticated means for managing flexibility both at short and long-term, which will be needed, requiring smart tools and methods”.

Flexibility will be managed with “equipment/processes within the perimeter of the electric system and equipment/processes pertaining to other domains and therefore typically not controllable by electric grid operators, which have to respect working criteria, needs and constraints typical of such external domains”.

**Figure 3-11** shows the scheme of flexibility for electricity grid operators showcases the breadth of communication coordination needs between operators and smart energy components and system energy vectors.

Grid use	Flexible generation	Flexible loads	Storage within electric system	Storage in other energy systems
<ul style="list-style-type: none"> <li>- Extended use of grid components</li> <li>- Interconnections</li> <li>- Exchanges with neighbouring areas</li> </ul>	<ul style="list-style-type: none"> <li>- Traditional plants' modulation</li> <li>- Enhanced ancillary services</li> <li>- Improved performances (ramps, response speed, capability range, start-stop sequences, duty cycles)</li> </ul>	<ul style="list-style-type: none"> <li>- Demand response</li> <li>- Interruptible customers</li> <li>- Balancing services</li> <li>- Aggregators</li> <li>- Market &amp; trading mechanisms</li> <li>- Smart EV charging</li> </ul>	<ul style="list-style-type: none"> <li>- Batteries</li> <li>- Fly wheels</li> <li>- CAES/LAES</li> <li>- Supercapacitors</li> <li>- Pump Hydro</li> </ul>	<ul style="list-style-type: none"> <li>- Electric vehicles</li> <li>- Thermal</li> <li>- Thermochemic.</li> <li>- Chemicals</li> <li>- Gases/Liquids</li> </ul>

<sup>11</sup> [https://www.etip-snet.eu/wp-content/uploads/2019/03/ETIP\\_SNET\\_HolisticArchitecture\\_2019\\_04\\_01\\_Final.pdf](https://www.etip-snet.eu/wp-content/uploads/2019/03/ETIP_SNET_HolisticArchitecture_2019_04_01_Final.pdf)

<sup>12</sup> ETIP SNET WG1 White Paper: Sector Coupling: Concepts, State-of-the-art and Perspectives – February 2019

### Figure 3-11 Scheme of flexibility means for electricity grid operators

The introduction of 5G technology by energy suppliers, is expected to facilitate more detailed data faster, while ensuring low latency over farther distances, while putting pressure on legacy data management systems to ensure resilient, flexible and continuous application delivery. Moreover, the introduction of 5G will enable future use cases and applications areas in the evolving energy sector:

- Drones for physical Grid observability
- Remote assets – Wind parks
- Digital Twin applications
- Use of Blockchain and smart contracts tech
- Further integration with other vectors such as water
- Stepping outside the smart city environment into the Smart Ports
- *5G integration in Industry 4.0 and smart energy grid concepts, see 5G-VIMA*

While the energy sector is currently undergoing major transformational change at every stage and every operational level the evolving technologies effective implementation, the sustainability of the solutions coupled with ensuring Return of Investment (ROI) of the new adaptations is on the forefront of the decision-makers agenda.

## 4 Conclusions

It is expected that 5G systems will extend mobile communication services beyond mobile telephony, mobile broadband, and massive machine-type communication into new application domains, so-called vertical domains.

The Release 1.0 of this report highlighted specific IoT vertical domain use cases and determined the specific requirements they impose on the network infrastructure. The Release 2.0 provided six additional use cases of which four are summaries of use cases defined by 3GPP SA1. These use cases and requirements can be used by SDOs (Standards Developing Organizations), such as 3GPP, ITU-T or IEEE to derive requirements for automation in vertical domains focusing on critical communications. The Release 3.0 of this report provides three additional use cases:

- Home Energy Display (Smart Energy type of use case);
- Holographic Meetings (Cross-vertical type of use case);
- All-Stop” in Mining and Construction Site Applications (Smart Manufacturing type of use case).

The IoT vertical domain use cases that have been presented in this Issue of this report are

- being proposed by AIOTI members and are derived from IoT projects where they participated or are currently participating or
- summaries of use cases defined by 3GPP SA1

The presented IoT vertical domains are: Smart Mobility, Smart City, Smart Energy, Smart Agriculture, Smart Manufacturing and Smart Health.

Regarding requirements that these use cases are imposing on the underlying communication network infrastructure the following key conclusions have been derived:

- Smart Mobility: Most of the 5G promises on performance capabilities, see [1] can be used to support the requirements imposed by the Smart Mobility use cases presented in this Issue of this report. The following Smart Mobility (Vehicle Monitoring) use case requirements are different than the 5G promises on performance capabilities, see [1]:
  - Range distance between communication neighbours: > 1km (long range)
  - Nonstandard operating conditions:
    - Possible powered device with > 1 day lifetime
  - Technology availability: > 15 years
  - SLA tooling: SLA monitoring
- Smart Agriculture: Most of the 5G promises on performance capabilities, see [1] can be used to support the requirements imposed by the Smart Agriculture use cases presented in this Issue of this report. The following Smart Agriculture (Smart Irrigation) use case requirements are different than the 5G promises on performance capabilities, see [1]:
  - Range distance between communication neighbours: < 10 km
  - Nonstandard operating conditions:
    - Possible powered device with > 1 year lifetime
  - SLA tooling: SLA monitoring
  - Technology availability: > 25 years
- Smart City: Most of the 5G promises on performance capabilities, see [1] can be used to support the requirements imposed by the Smart City use cases presented in this Issue of this report. The following Smart City use cases impose requirements that are different than the 5G promises on performance capabilities, see [1]:
- Public warning system in critical infrastructures use case:
  - Required Reliability 99,99999%
- UAV as MEC nodes for emergency operations support use case:
  - Radio cell range:
    - For cellular based transmissions: over 1 km transmission distances are required
    - For LP-WAN based transmissions: 10 km LOS and 4km NoLOS

- Smart Energy: Most of the 5G promises on performance capabilities, see [1] can be used to support the requirements imposed by the Smart Energy use cases presented in this Issue of this report. The Smart Energy (cross-vertical) requirements are different than the 5G promises on performance capabilities, see [1]:
  - Real time capability latency:
    - Medium voltage: 25ms
    - High Voltage: 5ms (long range)
  - Real time capability jitter:
    - Medium Voltage: 25 ms
    - High voltage: 1 ms
  - Time period information loss during failures:
    - Low voltage: minutes
    - Medium voltage: 25 ms
    - High voltage: seamless failover
  - Reliability:
    - Low voltage: 98%
    - Medium voltage: 99,9%
    - High voltage: 100%
  - Highly decentralized power system monitoring data collection rate: In case of increased decentralized energy production, high sampling rate might be required to balance the reactive/active power, power frequency and phasing, where the data collection time period is in the order of equal or less than 20 milliseconds
- Smart Manufacturing: Most of the 5G promises on performance capabilities, see [1] can be used to support the requirements imposed by the Smart Manufacturing use cases presented in this Issue of this report. The Smart Manufacturing (cross-vertical) requirements are different than the 5G promises on performance capabilities, see [1]:
- Communication in car manufacturing
  - peak aggregated user-experienced data rates for file transfers: at least 10 Gbit/s within an area of 500 m<sup>2</sup>
  - Positioning accuracy: < 1m
- High performance manufacturing
  - 5G system shall support clock synchronization defined by IEEE 802.1AS across 5G-based Ethernet links and other Ethernet transports such as wired and optical (supported by 5G in 3GPP Rel 16)
- Mobile control with safety
  - The 5G system shall support an indoor positioning service within factory danger zones with horizontal positioning accuracy better than 1 m, [99.9%] availability, heading < 0,52 rad and latency for positioning estimation of mobile device [< 1 s].
  - The 5G system shall support a communication service availability exceeding at least 99,9999%, ideally even 99,999999%

- Smart Health: Most of the 5G promises on performance capabilities, see [1] can be used to support the requirements imposed by the Smart Health use cases presented in this Issue of this report. The Smart Health (cross-vertical) requirements are different than the 5G promises on performance capabilities, see [1]:
- Intelligent Emergency Response Systems
  - The 5G system shall provide suitable APIs to allow use of a trusted 3rd party provided integrity protection mechanism for data exchanged with an authorized UE served by a 5G communication service.
  - Non-functional requirements – possible consideration includes:
    - The 5G system shall be able to ensure the confidentiality and integrity of data for/from the remote fall detector and all devices in indirect communications.
    - All requirements related to security management in private network
    - The 5G system shall provide a mechanism for denial-of-service prevention.
- Tactile Internet: Most of the 5G promises on performance capabilities, see [1] can be used to support the requirements imposed by the Tactile Internet use cases presented in this Issue of this report. The following Tactile Internet (cross-vertical) requirements are different than the 5G promises on performance capabilities, see [1]:
  - Reliability: 99.999 – 99.99999%
- Holographic Interaction: Most requirements are based on [44]. The following Holographic Interaction requirements are different than the 5G promises on performance capabilities, see [1]:
  - Required Reliability 99,99999%

This report includes as well a section that is dedicated to "emerging topics".

Release 1.0 included the following subsections:

- the first topic is a more general view on the "Tactile Internet of Things" and as such closely related to the use case in chapter 2.7.2;
- the second topic "5G Non-public Networks and Network Slicing" is reflecting on new options and flexibility of network enrolments once the full set of 5G features (in particular network slicing) is available;

Release 2.0 included the following subsection:

- ETSI ITS G5 versus 3GPP LTE-V2X, which are two key technologies considered today for intelligent transportation systems

Release 3.0 includes the following additional subsections:

- Overview of the 'Green Deal';
- IoT and 5G frequency spectrum;
- 5G promise towards the evolving energy sector.

More topics will be added in upcoming Issues of this report.



## Annex I References

- [1] 5G Vision, The 5G Infrastructure Public Private Partnership: the next generation of communication networks and services, 5GPPP, February 2015, to be retrieved via: <https://5g-ppp.eu/wp-content/uploads/2015/02/5G-Vision-Brochure-v1.pdf>
- [2] D. Evans, "The Internet of Things: How the Next Evolution of the Internet is Changing Everything," [Online]. Available: [https://www.cisco.com/c/dam/en\\_us/about/ac79/docs/innov/IoT\\_IBSG\\_0411FINAL.pdf](https://www.cisco.com/c/dam/en_us/about/ac79/docs/innov/IoT_IBSG_0411FINAL.pdf).
- [3] AIOTI WG06 (Smart Farming and Food Security), "Broadband Requirements for farming and rural uses," 2016.
- [4] Siemens AG, "5G communication networks: Vertical industry requirements," 11 2016. [Online]. Available: [http://www.virtuwind.eu/\\_docs/Siemens\\_PositionPaper\\_5G\\_2016.pdf](http://www.virtuwind.eu/_docs/Siemens_PositionPaper_5G_2016.pdf).
- [5] 5G-PPP, "5G Empowering Vertical Industries," 02 2016. [Online]. Available: [https://5g-ppp.eu/wp-content/uploads/2016/02/BROCHURE\\_5PPP\\_BAT2\\_PL.pdf](https://5g-ppp.eu/wp-content/uploads/2016/02/BROCHURE_5PPP_BAT2_PL.pdf).
- [6] "5G and Energy", 5G Infrastructure Association, September 2015 (visited in May 018) [https://5g-ppp.eu/wp-content/uploads/2014/02/5G-PPP-White\\_Paper-on-Energy-Vertical-Sector.pdf](https://5g-ppp.eu/wp-content/uploads/2014/02/5G-PPP-White_Paper-on-Energy-Vertical-Sector.pdf)
- [7] Recommendation ITU-T Y.3502, Information technology - Cloud computing - Reference architecture, ITU-T, 2014.
- [8] 5G PPP, "5G Vision." (<https://5g-ppp.eu/wp-content/uploads/2015/02/5G-Vision-Brochure-v1.pdf>)
- [9] B. Badic, C. Drewes, I. Karls, and M. Mueck, Rolling Out 5G. Apress, 2016.
- [10] P. F. E Silva, V. Kaseva, and E. S. Lohan, "Wireless positioning in IoT: A look at current and future trends," Sensors (Switzerland), vol. 18, no. 8, pp. 1–19, 2018.
- [11] J. Olsen, "Network-Based Time Delivery for 5G: Low Latency, Scalable Synchronization in Highly." [Online]. Available: <https://www.microsemi.com/blog/2018/07/10/network-based-time-delivery-for-5g-low-latency-scalable-synchronization-in-highly/>.
- [12] I. Sg et al., "IEEE 1588 Precision Time Protocol (PTP) in ITU-T Standards," pp. 1–16, 2008.
- [13] IEEE Std 1588-2008, "IEEE Standard for a Precision Clock Synchronization Protocol for Networked Measurement and Control Systems," Society, vol. 2008, no. July, pp. c1-269, 2008.
- [14] J. C. Eidson, Measurement, Control, and Communication Using IEEE 1588. Springer Science & Business Media, 2006.
- [15] Recommendation 3GPP SA1 TR 22.804, Study on Communication for Automation in Vertical Domains, 3GPP, Release 16, v16.2.0, December 2018.

- [16] Recommendation 3GPP SA1 TR 22 821, Feasibility Study on LAN Support in 5G, Release 16, v16.1.0, June 2018.
- [17] Journal of Telemedicine and Telecare, Volume 11, Number 4, 2005.
- [18] Recommendation 3GPP TR 22.826, Study on Communication Services for Critical Medical Applications, Release 17, V0.1.0, November 2018
- [19] IEEE Communications Society/Standards Development Board, Tactile Internet Working Group, online at: <http://grouper.ieee.org/groups/1918/1/>
- [20] O. Vermesan and J. Bacquet (Eds.). Next Generation Internet of Things - Distributed Intelligence at the Edge and Human Machine-to-Machine Cooperation, ISBN: 978-87-70220-07-1, River Publishers, Gistrup, 2018. Online at: [https://european-iot-pilots.eu/wp-content/uploads/2018/11/Next\\_Generation\\_Internet\\_of\\_Things\\_Distributed\\_Intelligence\\_at\\_the\\_Edge\\_IERC\\_2018\\_Cluster\\_eBook\\_978-87-7022-007-1\\_P\\_Web.pdf](https://european-iot-pilots.eu/wp-content/uploads/2018/11/Next_Generation_Internet_of_Things_Distributed_Intelligence_at_the_Edge_IERC_2018_Cluster_eBook_978-87-7022-007-1_P_Web.pdf)
- [21] Upcoming Delegated Act on "Cooperative Intelligent Transport Systems" (C-ITS). BitKom, Position paper, August 2018.
- [22] C-ITS platform Phase II - Cooperative Intelligent transport Systems towards Cooperative, connected and Automated Mobility, (Final report Phase II). Chaired by the EC, September 2017, online at: <https://ec.europa.eu/transport/sites/transport/files/2017-09-c-its-platform-final-report.pdf>
- [23] Results of C-ITS Platform Phase II - Certificate Policy for Deployment and Operation of European Cooperative Intelligent Transport Systems (C-ITS), Release 1.1. Chaired by EC, June 2018, online at: [https://ec.europa.eu/transport/sites/transport/files/c-its\\_certificate\\_policy\\_v1.1.pdf](https://ec.europa.eu/transport/sites/transport/files/c-its_certificate_policy_v1.1.pdf)
- [24] Results of C-ITS Platform Phase II - Security Policy & Governance Framework for Deployment and Operation of European Cooperative Intelligent Transport Systems (C-ITS). Release 1, December 2017, online on: [https://ec.europa.eu/transport/sites/transport/files/c-its\\_security\\_policy\\_release\\_1.pdf](https://ec.europa.eu/transport/sites/transport/files/c-its_security_policy_release_1.pdf)
- [25] ETSI TS 103 301 V1.1.1(2016-11): Technical Specification - Intelligent Transport Systems (ITS); Vehicular Communications; Basic Set of Applications; Facilities layer protocols and communication requirements for infrastructure services, online at: [https://www.etsi.org/deliver/etsi\\_ts/103300\\_103399/103301/01.01.01\\_60/ts\\_103301v010101p.pdf](https://www.etsi.org/deliver/etsi_ts/103300_103399/103301/01.01.01_60/ts_103301v010101p.pdf)
- [26] ETSI TC ITS, Intelligent Transport Systems (ITS); Vehicular Communications; Basic Set of Applications; Definitions, Std. ETSI TR 102 638 V1.1.2, 2015.
- [27] 3GPP TR 22.886 V1.0.0: Study on enhancement of 3GPP support for 5G V2X services (Release 15), 3GPP Std., November 2016
- [28] NGMN Alliance, "NGMN perspectives on vertical industries and implications for 5g," 2015. Available online: [https://www.ngmn.org/uploads/media/160610\\_NGMN\\_Perspectives\\_on\\_Vertical\\_Industries\\_and\\_Implications\\_for\\_5G\\_v1\\_0.pdf](https://www.ngmn.org/uploads/media/160610_NGMN_Perspectives_on_Vertical_Industries_and_Implications_for_5G_v1_0.pdf)
- [29] 3GPP TR 22.186 V15.0.0: Service requirements for enhanced V2X scenarios

- (Release 15), 3GPP Std., March 2017.
- [30]3GPP TS 22.261 v16.5.0 (2018-09). *3rd Generation Partnership Project; Technical Specification Group Services and System Aspects; Service requirements for the 5G system; Stage 1 (Release 16)*. 5G and 3GPP September 2018. Online at: [http://www.3gpp.org/ftp/specs/archive/22\\_series/22.261/22261-g50.zip](http://www.3gpp.org/ftp/specs/archive/22_series/22.261/22261-g50.zip)
- [31]NGMN 5G White paper, (v1.0). NGMN Alliance, February 2015. Online at: [https://www.ngmn.org/fileadmin/ngmn/content/downloads/Technical/2015/NGMN\\_5G\\_White\\_Paper\\_V1\\_0.pdf](https://www.ngmn.org/fileadmin/ngmn/content/downloads/Technical/2015/NGMN_5G_White_Paper_V1_0.pdf)
- [32]Recommendations for NGMN KPIs and Requirements for 5G, NGMN Alliance, June 2016. Online at: [https://www.ngmn.org/fileadmin/user\\_upload/160603\\_Annex\\_-\\_NGMN\\_Liaison\\_to\\_3GPP\\_RAN\\_72\\_v1\\_0.pdf](https://www.ngmn.org/fileadmin/user_upload/160603_Annex_-_NGMN_Liaison_to_3GPP_RAN_72_v1_0.pdf)
- [33]CLEPA position on “short range” V2V, V2P and V2I within C-ITS communication technologies (5.9 GHz frequency band), October 2018, online at: <https://clepa.eu/wp-content/uploads/2018/11/2018-12-CLEPA-position-5.9GHz-20180926-FINAL.pdf>
- [34]G. P. Fettweis, “The Tactile Internet: Applications and Challenges,” *IEEE Veh. Technol. Mag.*, vol. 9, no. 1, Mar. 2014, pp. 64–70.
- [35]E. Brynjolfsson and A. McAfee, *The Second Machine Age: Work, Progress, and Prosperity in a Time of Brilliant Technologies*, W. W. Norton and Company, Jan. 2014. online at: E. Brynjolfsson and A. McAfee, *The Second Machine Age*
- [36]IEEE Standards Association, P802.11bd - Standard for Information technology - Telecommunications and information exchange between systems Local and metropolitan area networks - Specific requirements - Part 11: Wireless LAN Medium Access Control (MAC) and Physical Layer (PHY) Specifications Amendment: Enhancements for Next Generation V2X , online at: [https://standards.ieee.org/project/802\\_11bd.html](https://standards.ieee.org/project/802_11bd.html)
- [37]Amy Nordrum, Kristen Clark, and IEEE Staff, “Everything You Need to Know About 5G,” *IEEE Spectrum*, January 27, 2017, online at <https://spectrum.ieee.org/video/telecom/wireless/everything-you-need-to-know-about-5g> Gerard Pogorel, “Spectrum 5.0: Re Thinking Spectrum Awards for Optimal 5G Deployment,” October 5, 2018.
- [38]James Kimery, “The Global Spectrum Challenge for 5G,” *Microwave Journal*, February 20, 2018, online at <http://www.microwavejournal.com/blogs/23-5g-and-beyond-national-instruments/post/29829-the-global-spectrum-challenge-for-5g>
- [39]NTIA, “WRC-19,” online at <https://www.ntia.doc.gov/category/wrc-19>
- [40]GSMA Spectrum, 5G Spectrum: Public Policy Position, July 2019, online at <https://www.gsma.com/spectrum/wp-content/uploads/2019/09/5G-Spectrum-Positions.pdf>
- [41]Huawei Technologies Co., Ltd. 2020, 5G Spectrum - Public Policy Position, Huawei White paper, February 2020
- [42]International Telecommunication Union, World Radio Communication Conference 2019 (WRC-19), Provisional Final Acts, Geneva, 2019.

- [43] European Commission: The European Green Deal. Communication from the Commission to the European Parliament, the European Council, the Council, the European Economic and Social Committee and the Committee of the Regions, Brussels, 11.12.2019 COM(2019) 640 final, [https://ec.europa.eu/info/sites/info/files/european-green-deal-communication\\_en.pdf](https://ec.europa.eu/info/sites/info/files/european-green-deal-communication_en.pdf).
- [44] O. Holland et al., "The IEEE 1918.1 "Tactile Internet" Standards Working Group and its Standards," in Proceedings of the IEEE, vol. 107, no. 2, pp. 256-279, Feb. 2019
- [45] J. Kiljander, 'D2.20 – Services and Modules for Oulu ICT Platform – Initial Version Making-City Project', Oulu, Finland, 2020.
- [46] F. Leferink, C. Keyer, and A. Melentjev, 'Static energy meter errors caused by conducted electromagnetic interference', IEEE Electromagn. Compat. Mag., vol. 5, no. 4, pp. 49–55, 2016, doi: 10.1109/MEMC.2016.7866234.
- [47] R. Q. Cetina, A. J. Roscoe, and P. S. Wright, 'A review of electrical metering accuracy standards in the context of dynamic power quality conditions of the grid', in 2017 52nd International Universities Power Engineering Conference (UPEC), 2017, pp. 1–5, doi: 10.1109/UPEC.2017.8231871.

## Annex II Template used for Use Case descriptions

### X. Use Case (title)

#### X.1 Description

- Provide motivation of having this use case, e.g., is it currently applied and successful; what are the business drivers, e.g., several stakeholder types will participate and profit from this use case
- Provide on a high level, the operation of the use case, i.e., which sequence of steps are used in this operation?

#### X.2 Source

- Provide reference to project, SDO, alliance, etc.

#### X.3 Roles and Actors

- Roles: Roles relating to/appearing in the use case
  - Roles and responsibilities in this use case, e.g., end user, vertical industry, Communication Network supplier/provider/operator, IoT device manufacturer, IoT platform provider, Insurance company, etc.
  - Relationships between roles
- Actors: Which are the actors with respect to played roles
- A detailed definition of the Roles and Actors is provided in [7].

#### **X.4 Pre-conditions**

- What are the pre-conditions that must be valid (be in place) before the use case can become operational

#### **X.5 Triggers**

- What are the triggers used by this use case

#### **X.6 Normal Flow**

- What is the normal flow of exchanged data between the key entities used in this use case: devices, IoT platform, infrastructure, pedestrians, vehicles, etc?

#### **X.7 Alternative Flow**

- Is there an alternative flow

#### **X.8 Post-conditions**

- What happens after the use case is completed

#### **X.9 High Level Illustration**

- High level figure/picture that shows the main entities used in the use case and if possible their interaction on a high level of abstraction

#### **X.10 Potential Requirements**

This section should provide the potential requirements and in particular the requirements imposed towards the underlying communication technology

These requirements can be split in:

- Functional requirements  
(to possibly consider them – but not limited to – with respect to the identified functions/capabilities)
- Non-functional requirements – possible consideration includes:
  - Flexibility
  - Scalability
  - Interoperability
  - Reliability
  - Safety
  - Security and privacy
  - Trust

As example of the format of such requirements is provided in Section 2.7.1.

## **X.11 Radio Specific requirements**

### **X.11.1 Radio Coverage**

- Radio cell range  
Specification of expected maximum and typical radio ranges (indicate if LOS/NoLOS)
- Does the radio link crosses public spaces? Or is it constrained to indoor or customer premises?
- Is Multicell required?  
(If YES, specify the required scope of the multicell arrangement. I.e. "building", "city", "global")
  - Is handover required? Seamless? Tolerable impact in delay and jitter?
- Mobility: maximum relative speed of UE/FP peers
- Special coverage needs: i.e., maritime, aerial
- 

### **X.11.2 Bandwidth requirements**

- Peak data rate
- Average data rate
- Is traffic packet mode or circuit mode?
  - If circuit mode, is isochronicity required?
  -

### **X.11.3 URLLC requirements**

- Required Latency  
(specify if it is one way or roundtrip)
- Required Reliability  
(i.e., 99,99999%)
- Maximum tolerable jitter
- 

### **X.11.4 Radio regimens requirements**

- Desired and acceptable radio regimens (describe the desired and acceptable radio regimens: I.e.: licensed - public mobile, licensed – specific license, license-exempt)

#### ***X.11.5 Other requirements***

- UE power consumption
  - Rechargeable or primary battery?
  - Acceptable battery life
- Is terminal location required? Location accuracy?

**Annex III Summary table from AIOTI WG06 report “Broadband Requirements for farming and rural uses” copied from [3]**

Use case	Relevance	Status	Bandwidth Download/Upload	Latency	Ubiquity / Coverage	Need for fixed/backhaul vs. wireless solutions	Satellite connectivity needed?	Demands a better performing broadband service?
1.a Precision farming: Live mapping of soil moisture	High	Planned	Mbps order	Not critical	Ubiquitous	-	No	Yes
1.b Precision farming: variable rate fertilization (including N-sensing)	High (economy- and environment-wise)	In place / Planned	-	Not critical	Ubiquitous	-	No	Yes
1.c Precision farming: Smart irrigation	High (economy- and	In place / Planned	Kbps order	Not critical	Rural areas where	No	No	No



Use case	Relevance	Status	Bandwidth Download/Upload	Latency	Ubiquity / Coverage	Need for fixed/backhaul vs. wireless solutions	Satellite connectivity needed?	Demands a better performing broadband service?
	environment-wise)				irrigation is used			
2. Wirelessly connected agricultural machinery	Medium-high	In place / planned	Kbps-Mbps (depending on application)	Critical / Non-critical, (depending on application)	Ubiquitous	Depending on market evolution	-	Yes (efforts already underway at standardization level)
3. Data-centric farm management	High	In place / planned	Mbps order	10's milliseconds order	Ubiquitous	Depending on aggregated demand in a rural area	Yes, if only affordable solution	Yes

Use case	Relevance	Status	Bandwidth Download/Upload	Latency	Ubiquity / Coverage	Need for fixed/backhaul vs. wireless solutions	Satellite connectivity needed?	Demands a better performing broadband service?
4. Remote video monitoring and videoconferencing in farming	Medium	Planned / Potentially needed	Mbps order	Non-critical (monitoring)	Large area coverage	Depending on aggregated demand in a rural area	Yes, if cost-effective for remote areas with no proper wireless connectivity	Yes
5. Connectivity to wind farms	Medium	In place / planned	Gbps order	Critical	Localized (fiber) connectivity	Fixed	No	Yes
6. General broadband use by rural citizens and businesses	High	In place	Gbps order	Varying (depending on application)	Populated rural areas	Depending on aggregated demand in a rural area	Yes, if only affordable solution	Yes

## Annex IV Editor and Contributors to this Deliverable

The document was written by several participants of the AIOTI WG03.

Editor:

- Georgios Karagiannis, Huawei
- Thomas Klein, IBM

Main Contributors:

- Angel Boveda, Wireless Partners S.L.L.
- Jacques Olaf Kruse Brandao, NXP
- Marco Carugi, Huawei
- John Davies, BT
- Miodrag Djurica, TNO
- Luis Perez-Freire, Gradiant
- David Christian Fürcho, NXP
- Patrick Guillemin, ETSI
- Juergen Heiles, Siemens
- Georgios Karagiannis, Huawei
- Hamid Karimi, Huawei
- Holger Kellerbauer, Caterpillar / CECE Digital Task Force
- Jean-Nicolas Louis, University of Oulu, Finland
- Aitor Corchero Rodriguez, EURECAT
- Natalie Samovich. Enercoutim
- Ramon Sanchez, University of Murcia, Spain
- Antonio Skarmeta, University of Murcia, Spain
- Pirkko Taskinen, University of Oulu, Finland
- Ranga Rao Venkatesha Prasad, Technical University Delft, the Netherlands
- Ovidiu Vermesan, SINTEF, Norway
- Jumoke Ogunbekun, ETSI STF 547,
- Joachim Koss, ETSI STF 547, Germany
- João Sarraipa, UNINOVA, Portugal
- Andreia Artifice, UNINOVA, Portugal

All rights reserved, Alliance for Internet of Things Innovation (AIOTI). The content of this document is provided 'as-is' and for general information purposes only; it does not constitute strategic or any other professional advice. The content or parts thereof may not be complete, accurate or up to date. Notwithstanding anything contained in this document, AIOTI disclaims responsibility (including where AIOTI or any of its officers, members or contractors have been negligent) for any direct or indirect loss, damage, claim, or liability any person, company, organisation or other entity or body may incur as a result, this to the maximum extent permitted by law.

## About AIOTI

AIOTI is the multi-stakeholder platform for stimulating IoT Innovation in Europe, bringing together small and large companies, start-ups and scale-ups, academia, policy makers and end-users and representatives of society in an end-to-end approach. We work with partners in a global context. We strive to leverage, share and promote best practices in the IoT ecosystems, be a one-stop point of information on all relevant aspects of IoT Innovation to its members while proactively addressing key issues and roadblocks for economic growth, acceptance and adoption of IoT Innovation in society.

AIOTI's contribution goes beyond technology and addresses horizontal elements across application domains, such as matchmaking and stimulating cooperation in IoT ecosystems, creating joint research roadmaps, driving convergence of standards and interoperability and defining policies. We also put them in practice in vertical application domains with societal and economic relevance.

AIOTI is a partner for the European Commission on IoT policies and stimulus programs, helping to identifying and removing obstacles and fast learning, deployment and replication of IoT Innovation in Real Scale Experimentation in Europe from a global perspective.

AIOTI is a member driven organisation with equal rights for all members, striving for a well-balanced representation from all stakeholders in IoT and recognizing the different needs and capabilities. Our members believe that we are the most relevant platform for connecting to the European IoT Innovation ecosystems in general and the best platform to find partners for Real Scale Experimentation.